



# INDUSTRIAL VALVES

Experience and Quality since 1889



# Company

## ▶ PRUSS ARMATUREN AG

After more than 10,000 successfully realised projects in many different sectors, we know exactly what matters.

## ▶ 125 years of experience

We have been working successfully for our customers for 125 years. We offer experience, expertise, tradition, development and progress.

## ▶ Our solutions

We deliver customised solutions and meet the highest requirements and quality standards.





**HANNEMANN&PRUSS GmbH**  
Kraftwerks- und Industriearmaturen

- ▶ Core business: Precision control valves
- ▶ Year of inception: 1889 / 1905
- ▶ Location: Hanover, Germany / Solingen, Germany
- ▶ Site: 13,000 sq.m
- ▶ Production area: 10,000 sq.m
- ▶ Staff: 93 / 7
- ▶ Turnover 2013: 22 € millions
- ▶ Export share: 60%

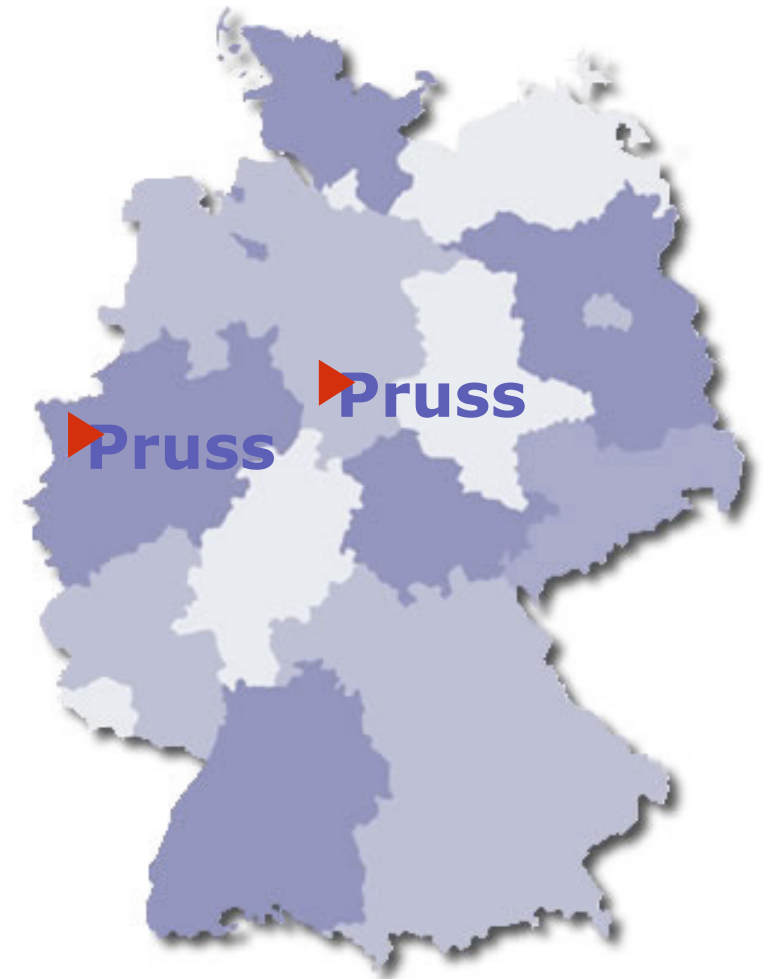



# Expertise and know-how

## ▶ Your specialist for power plants

Main technology partner  
for power plant systems  
manufacturers





## ▶ Your specialist in the field of oil + gas

Technology partners  
for valves in petro-  
chemical plants and  
off-shore



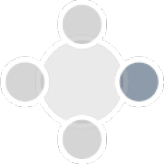

# Product areas and market segments

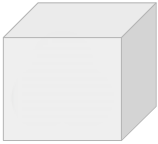
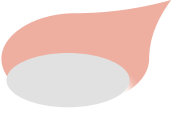
Branch	 <b>Power plants</b>	 <b>Oil and gas industry</b>	 <b>Iron and steel industry</b>	 <b>Petrochemicals</b>
Products	<ul style="list-style-type: none"> <li>Oil and gas control valves</li> <li>Feed water control valves</li> <li>Steam reduction valves</li> <li>Steam converting valves</li> <li>Water injection valves</li> <li>Condensation discharge regulator valves</li> </ul>	<ul style="list-style-type: none"> <li>Valves for oxygen, nitrogen</li> <li>Gas pressure regulators</li> <li>Storage valves and discharge valves</li> <li>Regulator valves</li> </ul>	<ul style="list-style-type: none"> <li>Cooling valves</li> <li>Valves for O<sub>2</sub>, N<sub>2</sub> and argon</li> </ul>	<ul style="list-style-type: none"> <li>Valves for chemical applications</li> <li>Bypass valves</li> </ul>
Applications	<ul style="list-style-type: none"> <li>Fuel regulation</li> <li>Feed water treatment</li> <li>Steam turbine</li> <li>Condenser</li> <li>Gas turbine</li> <li>Pipeline system</li> </ul>	<ul style="list-style-type: none"> <li>Gas separation system</li> <li>Caverns</li> <li>Gas compressors</li> </ul>	<ul style="list-style-type: none"> <li>Furnace</li> <li>Reduction systems</li> <li>Continuous casting systems</li> </ul>	<ul style="list-style-type: none"> <li>Cracker regenerators</li> <li>Chemical plants</li> </ul>

# Portfolio

▶ A broad spectrum of applications

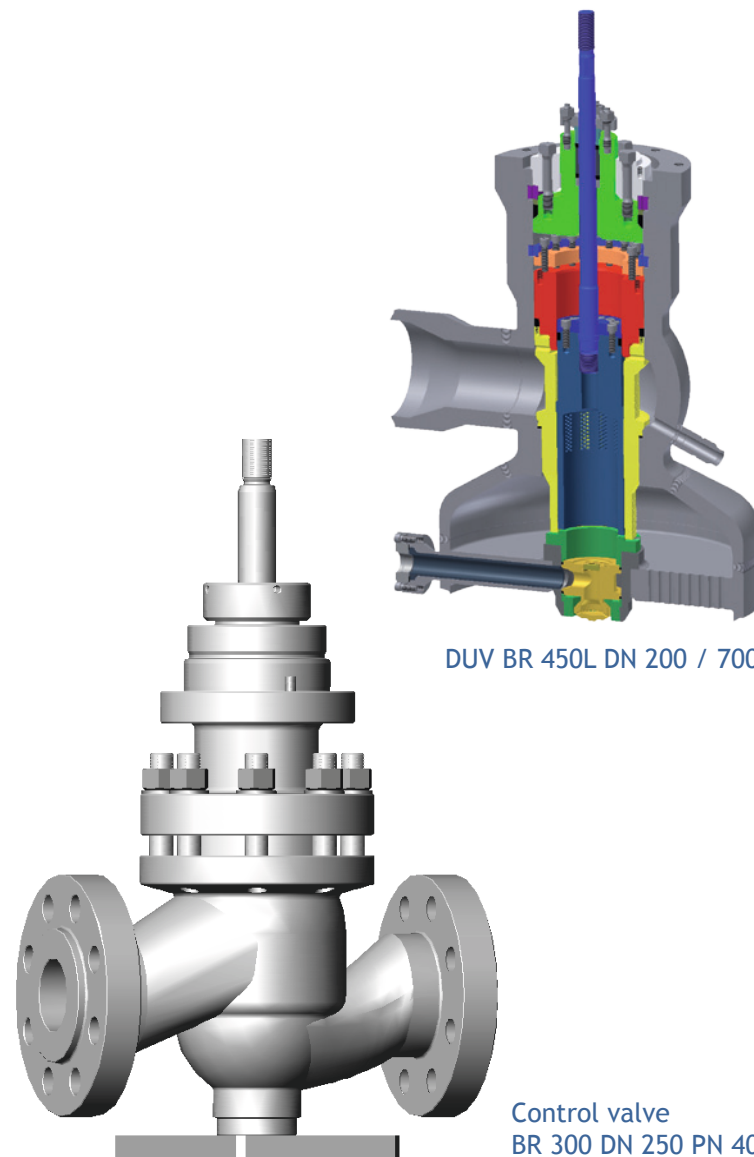
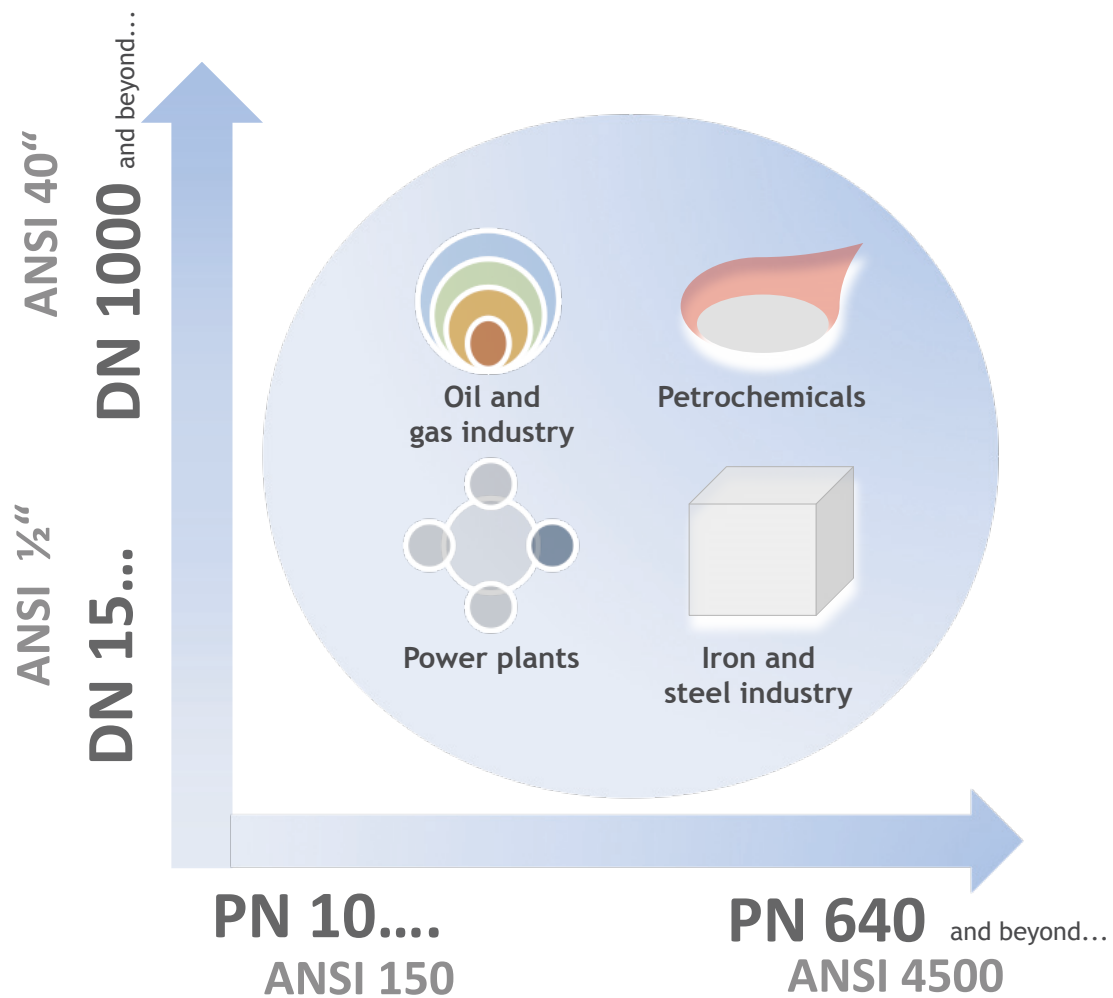

# Customised solutions based on our product lines

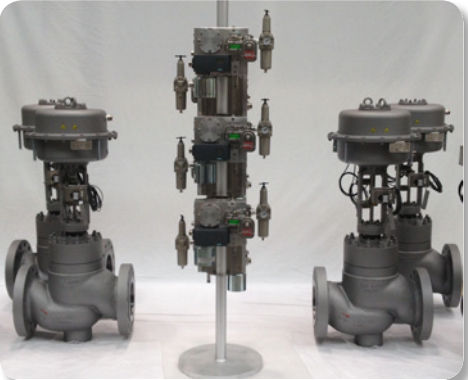

Pipeline control valves with detached control blocks



Steam conversion station as complete package

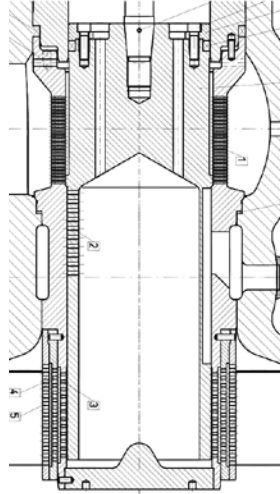

7-stage "whispering" turbine bypass



Compressor CV with floor pedestal



PRDS as controlled safety valve incl. component-tested steam rod



Stainless steel compressor control valves



"whispering" HP bypass



HP boiler control valves



# References

Power plants	Oil and gas industry	Iron and steel industry	Petrochemicals	Segment suppliers
          	               	     	     	      

# Quality characteristics



## High performance materials

The choice of exact fitting, high-quality raw materials guarantees long life and reliability even in the most extreme conditions.



## Leakage rates

As a result of constant refinement, we are in a position to offer our products permanently leakage-tight even in the most extreme operating conditions.



## Design and construction

Decades of experience enable us to offer the exactly right design for every application. For example, as the housings are spherical in shaped, the strength of the walls is kept nearly equal which has the advantage of avoiding tension caused by the accumulation of material. As a result, they can withstand fast heat-up rates.



## Characteristic curves / turndown ratio

Any characteristic curve is achievable, sometimes in conjunction with very extreme turndown ratios (250:1). If desired, we can document this on our fully automated, PTB certified Kvs test bench.



## Noise emissions

The avoidance of noise emissions through multi-stage, fully regulated inner parts and downstream silence packs, enables us to meet even the most demanding noise requirements.

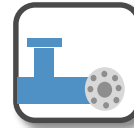

## Interfaces

We will be happy to supply flange connections in accordance with all known standards, incl. counter-flanges, seals and connecting pieces. We adapt the material of the weld ends, if required, to avoid mixed weldings or adapters on site.



## Ambient conditions

Individual designs can also cope with the most extreme ambient conditions, e.g.: spindle protection for use in desert climates or low temperature designs down to -60°C for pipeline applications.



## Ex protection

Explosive and flammable substances require special measures. Pruss valves can be supplied in all Ex protection classes.



## Drives

Whether pneumatic, hydraulic or electrical, whether from PRUSS or from well-known manufacturers, all drives are selected, adapted and adjusted to fit our valves, and subjected to a test run. If desired, we can document this process for you by means of our fully automated test bench.

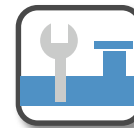

## Low maintenance design

As a result of many years of experience, constant refinement and modular design, we can offer you valves which are almost maintenance-free. Downtime for complicated, arduous repairs is a thing of the past with Pruss.

# Our valves

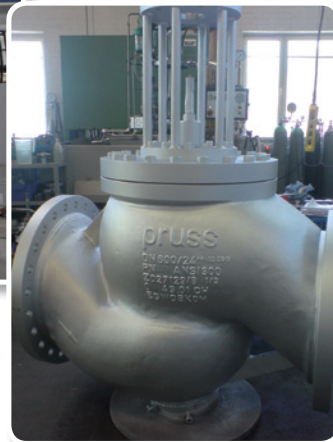
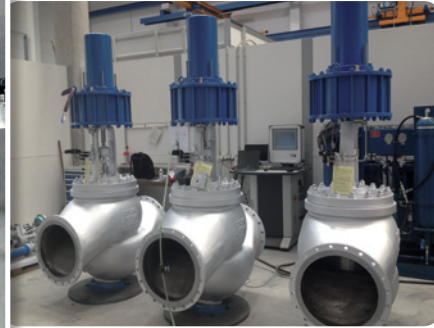
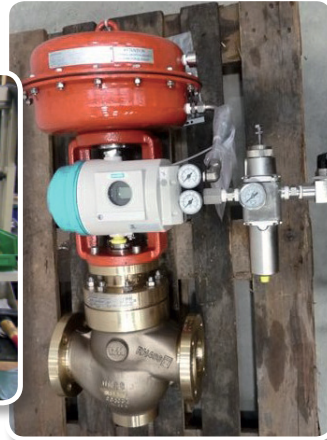
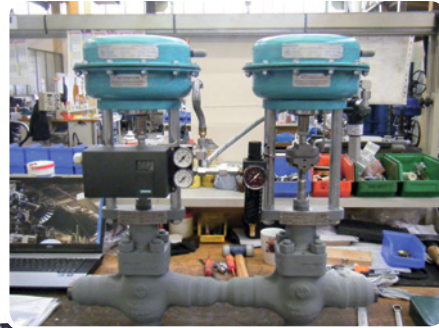



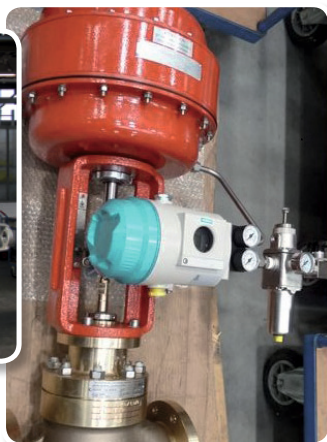
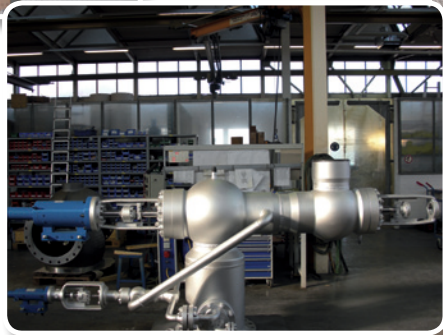
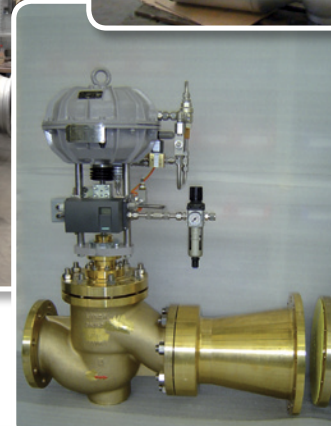
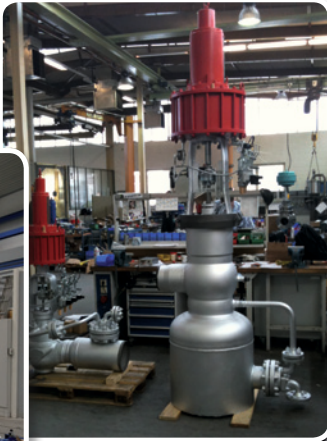



# Power plants: Gas and steam power plant



# Gas turbine

## Gas Package Siemens/ Westinghouse GT V94.3A (V84.3) Ring-Burner

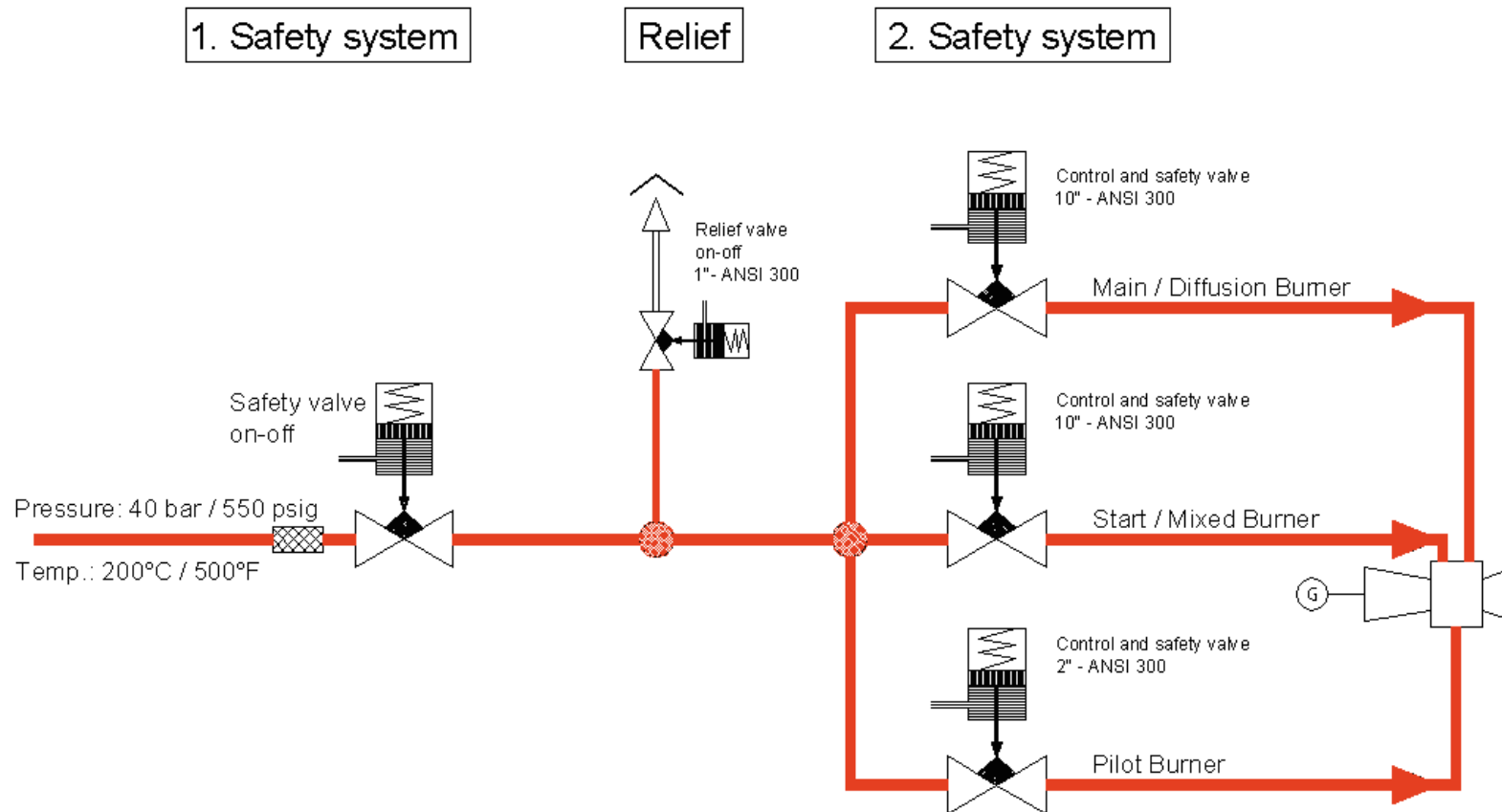



# Quick-action gas valve

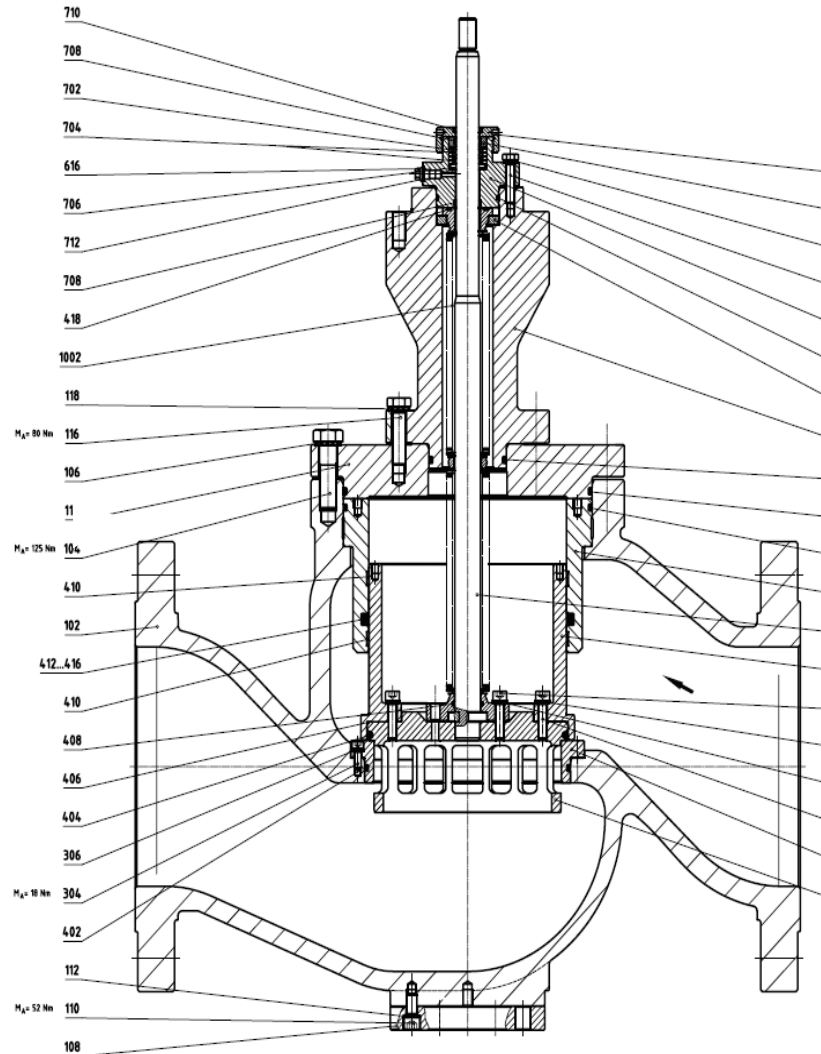

- ▶ **Application:** Gas-fired power plants
- ▶ **Product:** Gas turbine fuel valve, quick-action valve
- ▶ **Design:** Straight
- ▶ **Housing material:** Austenitic cast steel
- ▶ **Pipe connection:** Flanges
- ▶ **Valve plug type:** Slot plug
- ▶ **Valve seat seal:** Soft sealing
- ▶ **Spindle seal:** Bellow seal with additional safety gland packing
- ▶ **Drive type:** Hydraulic actuator
- ▶ **Control function and/or Safety function:** Fuel fed to gas burner in gas turbine, fast closing in < 0.25 sec if turbine trips, valve forms gas lock together with gas regulator valve
- ▶ **Highlights:** Tightly sealed even after 20,000 cycles, fully balanced

# Gas control valve with quick-action function

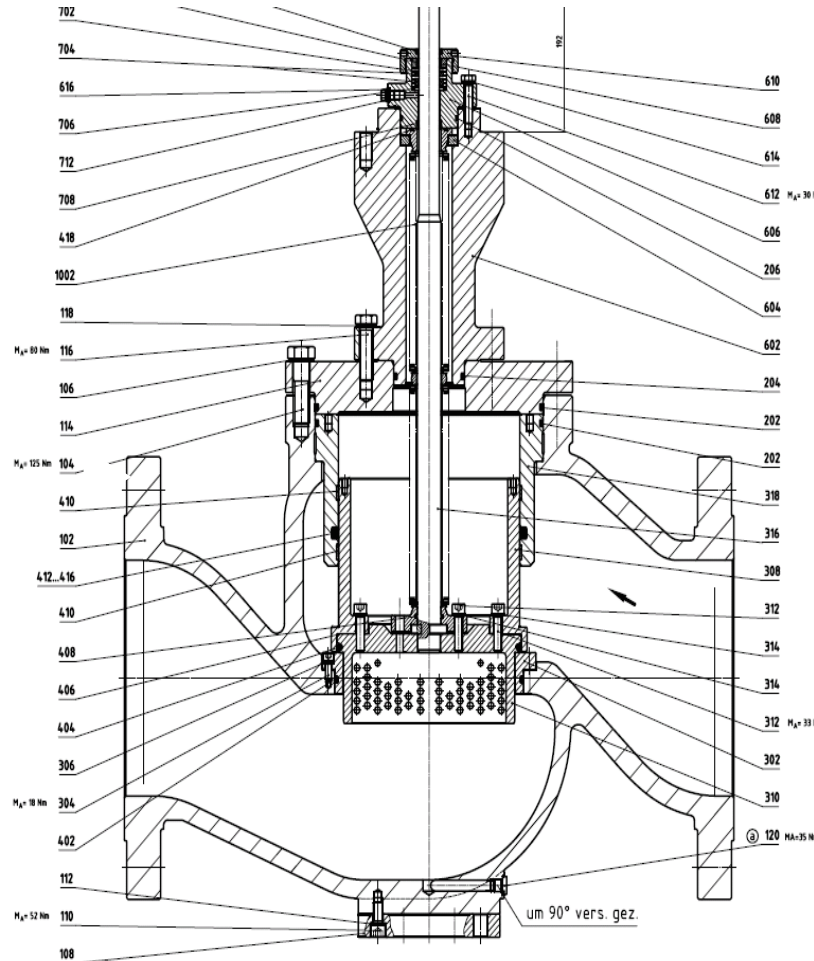

- ▶ **Application:** Gas-fired power plants
- ▶ **Product:** Gas turbine fuel valve, control valve with quick-action function
- ▶ **Design:** Straight
- ▶ **Housing material:** Austenitic cast steel
- ▶ **Pipe connection:** Flanges
- ▶ **Valve plug type:** Perforated plug
- ▶ **Valve seat seal:** Soft sealing
- ▶ **Spindle seal:** Bellow seal with additional safety gland packing
- ▶ **Drive type:** Hydraulic actuator
- ▶ **Control function and/or Safety function:** Fuel fed to gas burner in gas turbine, fast closing in < 0.25 sec if turbine trips, valve forms gas lock together with gas regulator valve
- ▶ **Highlights:** Tightly sealed, turndown ratio of 1 : 200, fully balanced



# Quick-action oil valve

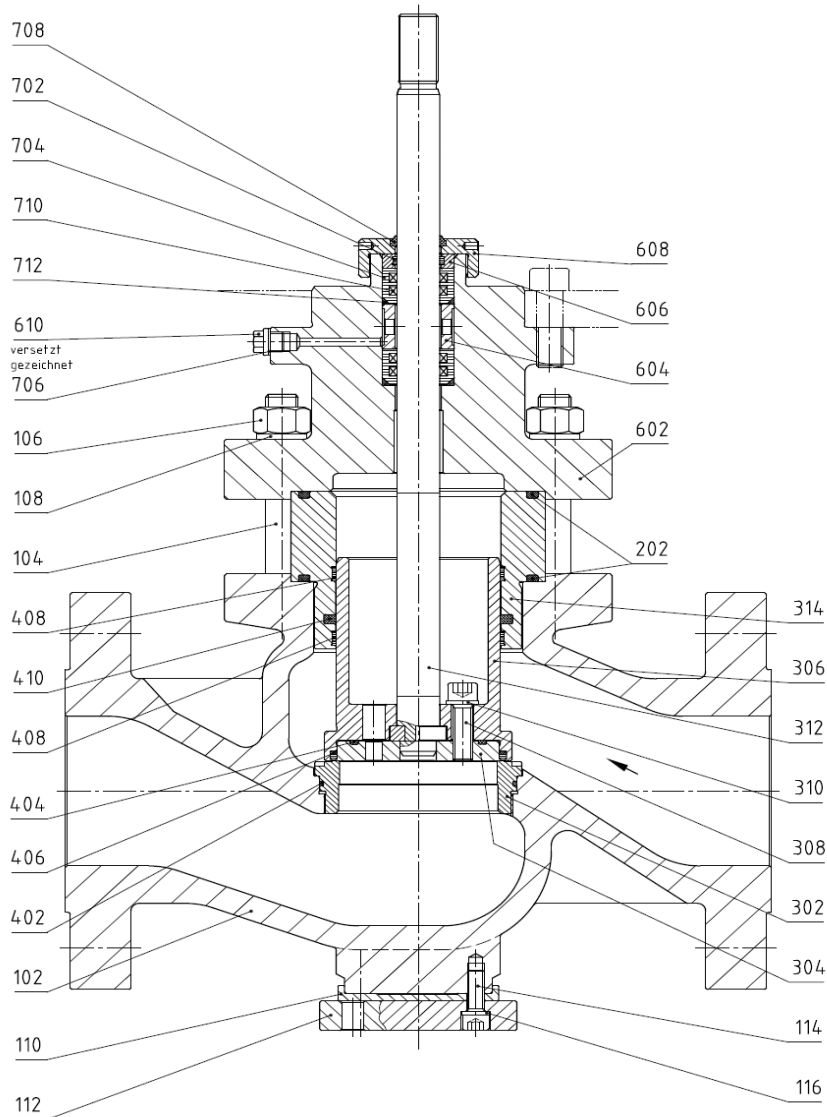

- ▶ **Application:** Gas and steam power plants, steam power plants, nuclear power plants
- ▶ **Product:** Oil on – off valve
- ▶ **Design:** Straight
- ▶ **Housing material:** Cast steel
- ▶ **Pipe connection:** Flanges
- ▶ **Valve plug type:** Flat plug
- ▶ **Valve seat seal:** Soft sealing
- ▶ **Spindle seal:** Soft sleeve
- ▶ **Drive type:** Electrical, pneumatic or hydraulic
- ▶ **Control function and/or Safety function:** Oil feed in oil system
- ▶ **Highlights:** Tightly sealed even after 20,000 cycles, fully balanced

# Oil control valve with quick-action function

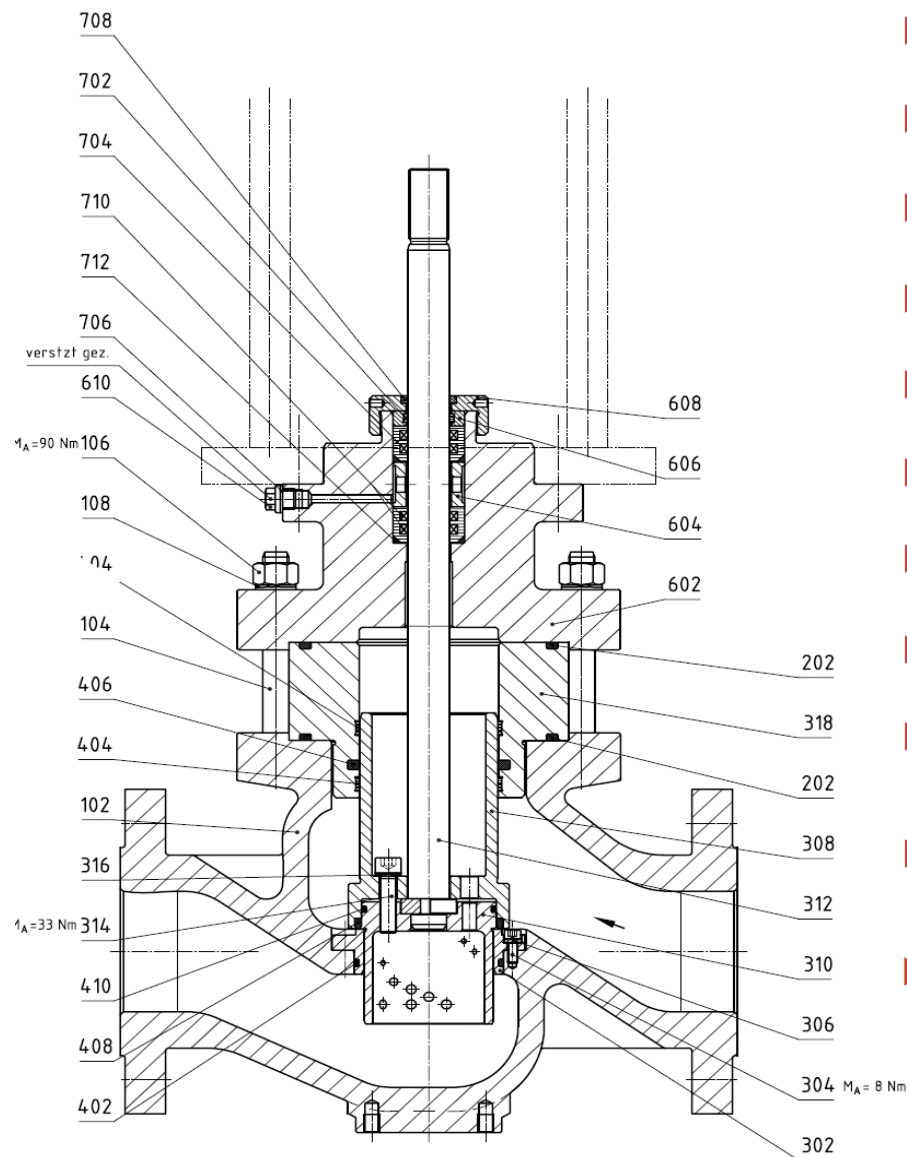

- ▶ **Application:** Gas-fired power plants
- ▶ **Product:** Oil control valve
- ▶ **Design:** Straight
- ▶ **Housing material:** Cast steel
- ▶ **Pipe connection:** Flanges
- ▶ **Valve plug type:** Perforated plug
- ▶ **Valve seat seal:** Soft sealing
- ▶ **Spindle seal:** Soft sleeve
- ▶ **Drive type:** Electrical, pneumatic or hydraulic
- ▶ **Control function and/or Safety function:** Oil feed in oil system
- ▶ **Highlights:** Tightly sealed even after 20,000 cycles, fully balanced



# Thermal power stations



# One supplier for the whole process

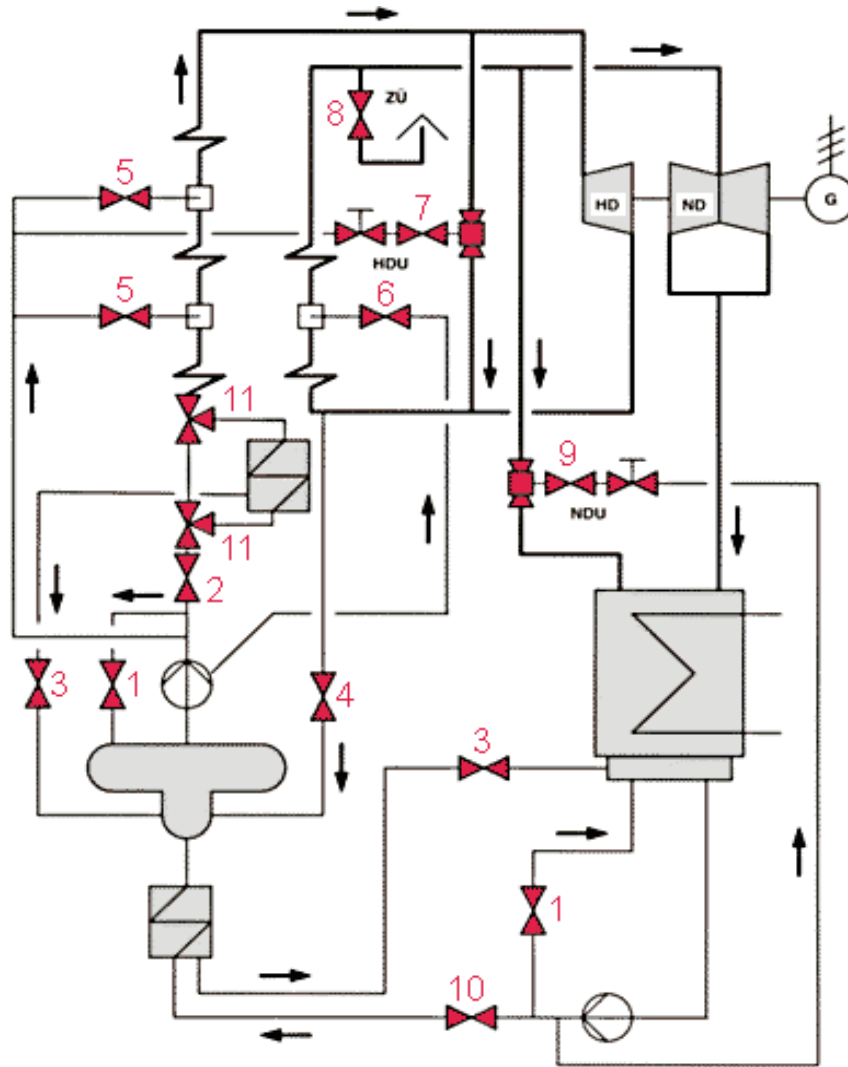

- ▶ 1 Minimum volume control valves
- ▶ 2 Feed water control valves
- ▶ 3 Level control valves
- ▶ 4 Steam reduction stations
- ▶ 5 Injection control valves
- ▶ 6 Injection control valves
- ▶ 7 HP bypass stations
- ▶ 8 Overheating safety valve
- ▶ 9 LP bypass stations
- ▶ 10 Condenser level control valves
- ▶ 11 Pre-heat protection



# Feed water control valve

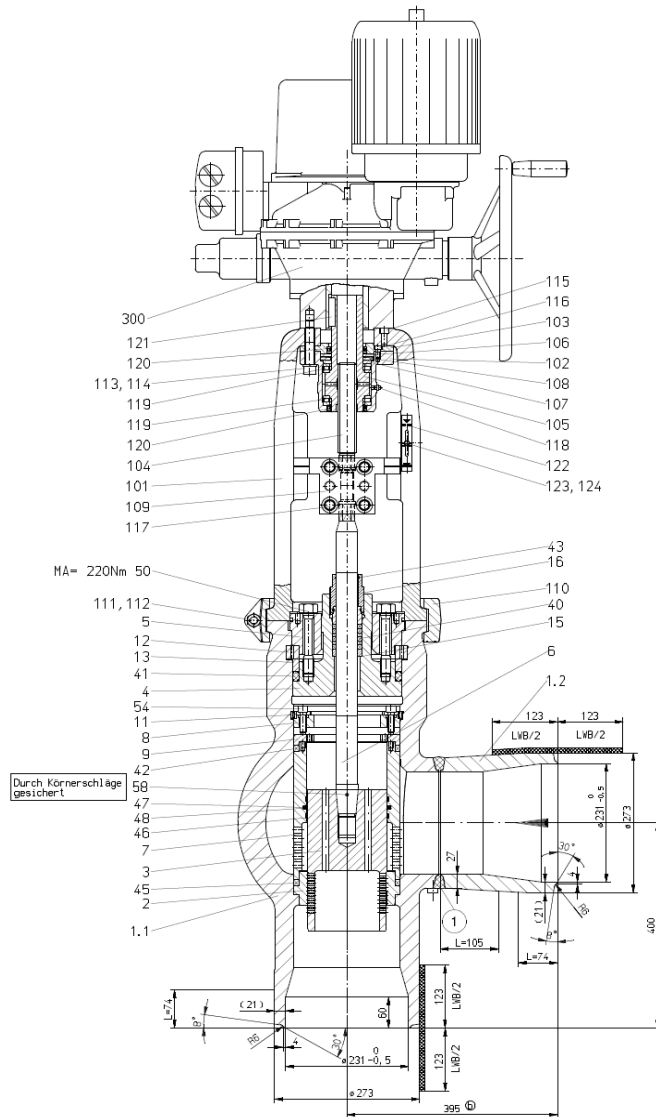

- ▶ **Application:** Gas and steam power plants, steam power plants, nuclear power plants
- ▶ **Product:** 100% feed water control valve
- ▶ **Design:** Angular form
- ▶ **Housing material:** Forged steel
- ▶ **Pipe connection:** Weld ends
- ▶ **Valve plug type:** Perforated plug
- ▶ **Valve seat seal:** Metallic
- ▶ **Spindle seal:** Gland packing with graphite packing
- ▶ **Drive type:** Electrical actuator
- ▶ **Control function and/or Safety function:** Regulating the feed water flow
- ▶ **Highlights:** Balanced, leakage rate A, inner parts inserted



# Feed water control valve

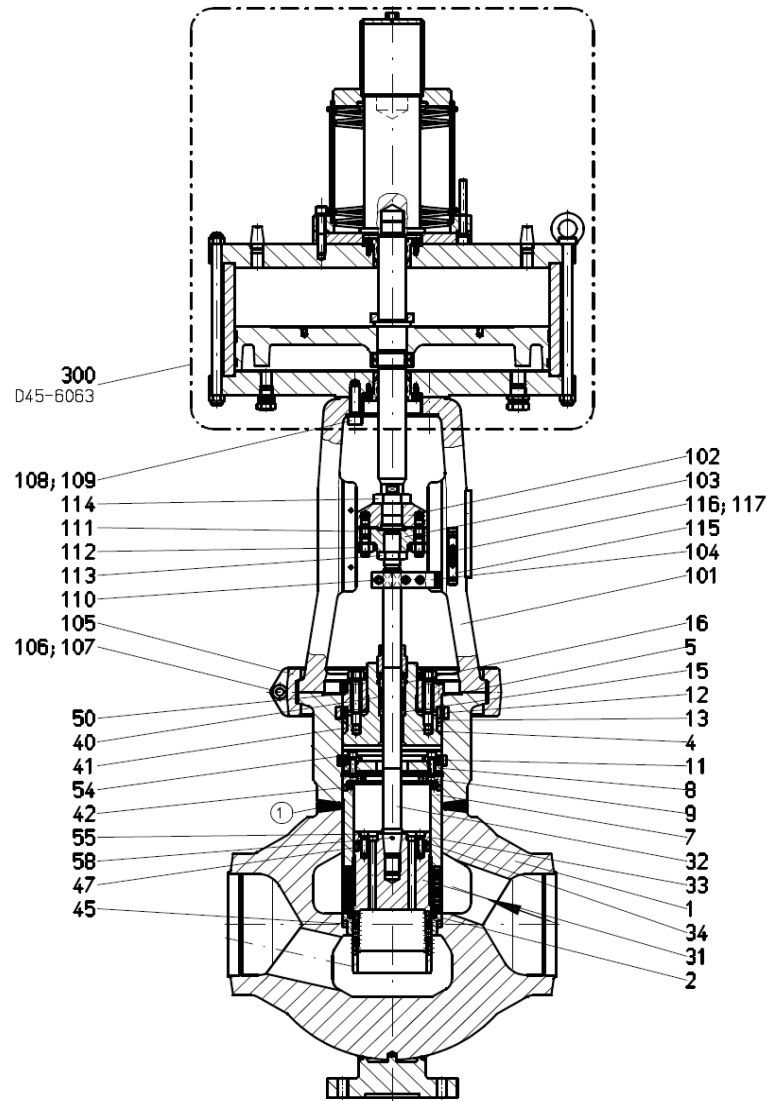

- ▶ **Application:** Gas and steam power plants, steam power plants, nuclear power plants
- ▶ **Product:** 100% feed water control valve
- ▶ **Design:** Straight
- ▶ **Housing material:** Forged steel
- ▶ **Pipe connection:** Weld ends
- ▶ **Valve plug type:** Two-stage throttle system consisting of perforated cage and perforated plug
- ▶ **Valve seat seal:** Metallic
- ▶ **Spindle seal:** Gland packing with graphite packing
- ▶ **Drive type:** Pneumatic piston drive
- ▶ **Control function and/or Safety function:** Regulating the feed water flow
- ▶ **Highlights:** Balanced, leakage rate A, inner parts inserted

# Feed water start-up control valve

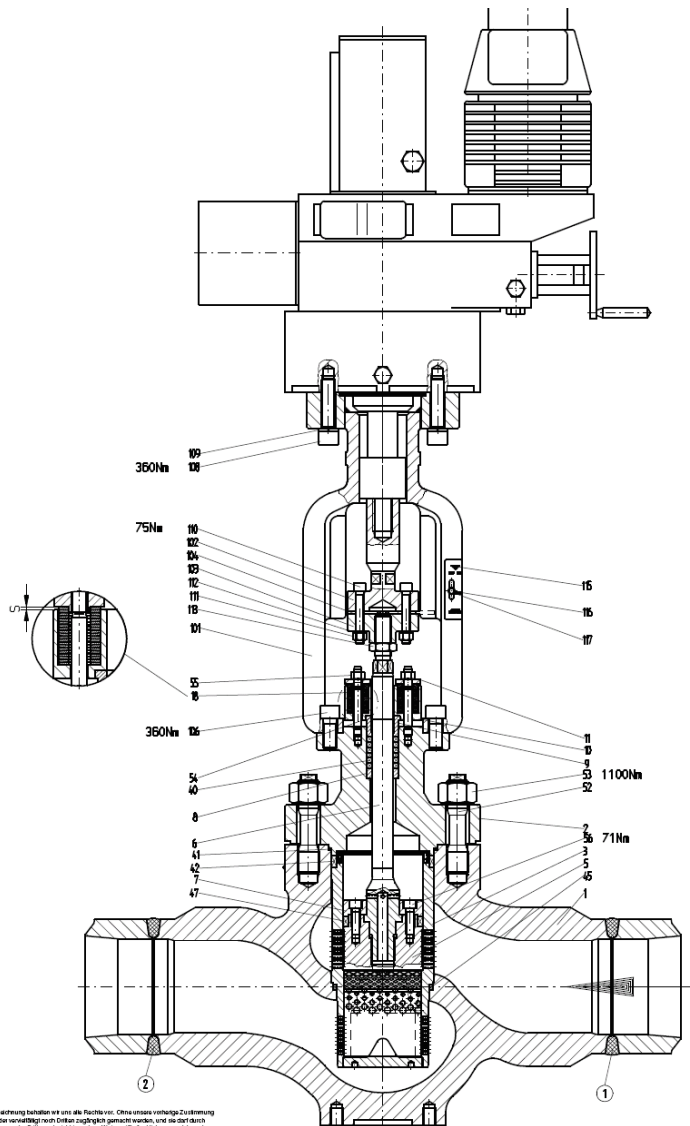

- ▶ **Application:** Gas and steam power plants, steam power plants, nuclear power plants
- ▶ **Product:** Feed water start-up control valve
- ▶ **Design:** Straight
- ▶ **Housing material:** Cast steel
- ▶ **Pipe connection:** Weld ends
- ▶ **Valve plug type:** Multi-stage throttle system consisting of perforated cage and labyrinth plug and seat
- ▶ **Valve seat seal:** Metallic
- ▶ **Spindle seal:** Gland packing with graphite packing in "life-loading design"
- ▶ **Drive type:** Electric actuator
- ▶ **Control function and/or Safety function:** Regulating feed water volume during start-up
- ▶ **Highlights:** Leakage rate A, economical cast housing

# Comb. start-up / full load feed water valve

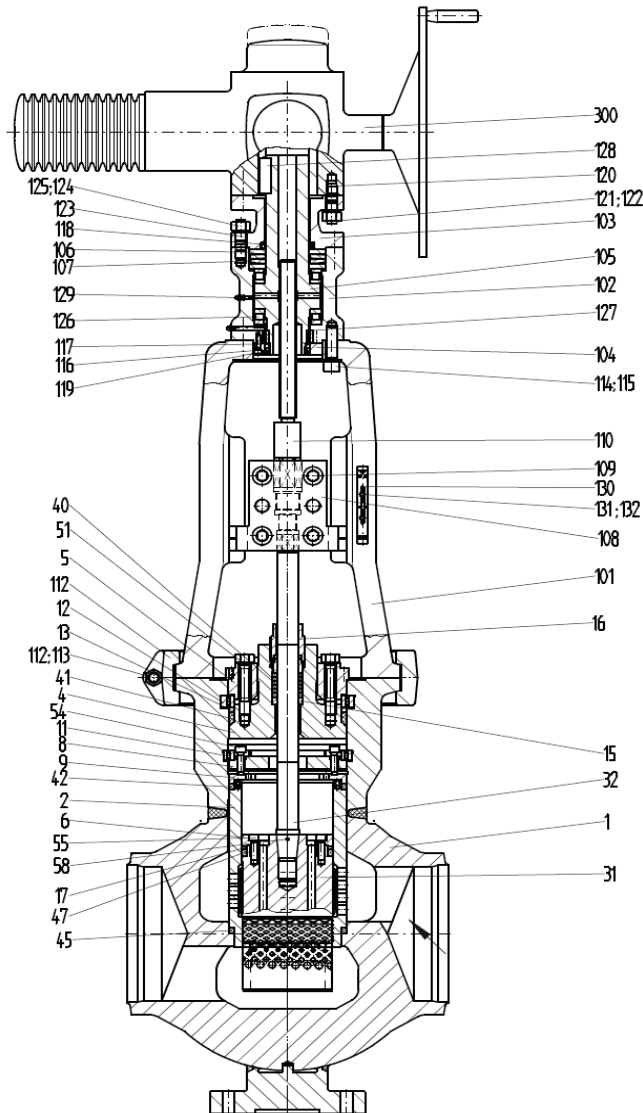

Ohne unsere vorherige Zustimmung  
nicht wachen, und sie darf durch  
einfache Mittel verändert werden.

- ▶ **Application:** Gas and steam power plants, steam power plants, nuclear power plants
- ▶ **Product:** Combined start-up and full load feed water control valve
- ▶ **Design:** Straight
- ▶ **Housing material:** Forged steel
- ▶ **Pipe connection:** Weld ends
- ▶ **Valve plug type:** Multi-stage throttle system consisting of perforated cage and labyrinth plug
- ▶ **Valve seat seal:** Metallic
- ▶ **Spindle seal:** Gland packing with graphite packing
- ▶ **Drive type:** Electric actuator
- ▶ **Control function and/or Safety function:** Regulating the feed water flow during start-up and at full load
- ▶ **Highlights:** Balanced, leakage rate A, inner parts inserted, reduction of extreme high DPs



# Boiler recirculation control valve

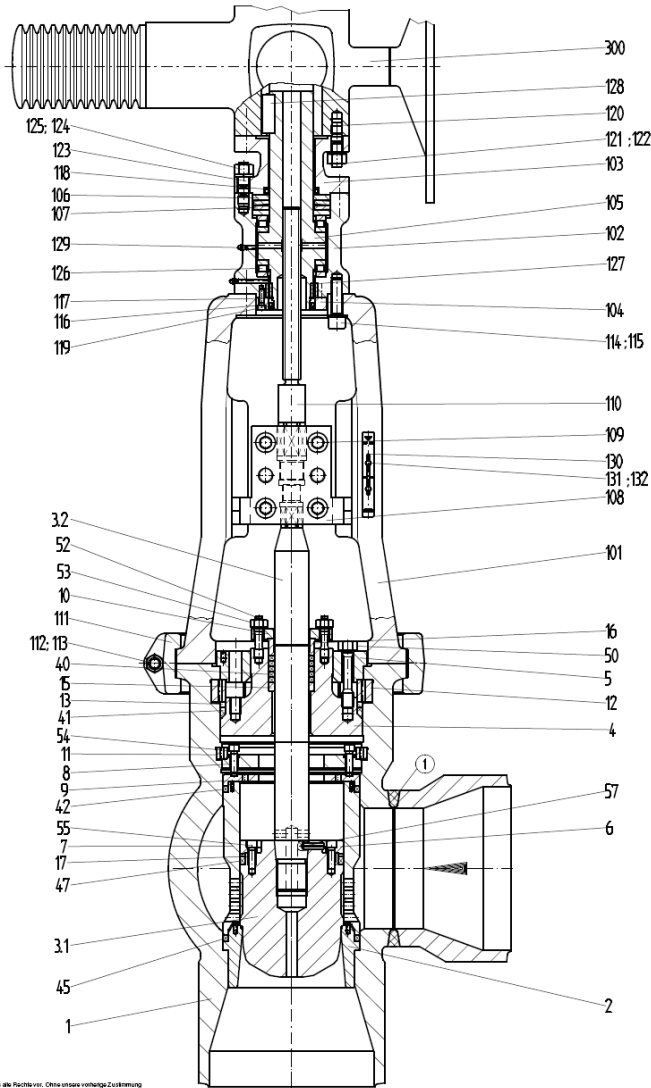

Alle Rechte vorbehalten. Ohne unsere vorherige Zustimmung  
kann weder das gesamte Material, noch die Einzelteile  
ohne unsere schriftliche Genehmigung verwendet werden.

- ▶ **Application:** Gas and steam power plants, steam power plants, nuclear power plants
- ▶ **Product:** Boiler start-up valve
- ▶ **Design:** Angular form
- ▶ **Housing material:** Forged steel
- ▶ **Pipe connection:** Weld ends
- ▶ **Valve plug type:** Parabolic plug
- ▶ **Valve seat seal:** Metallic
- ▶ **Spindle seal:** Gland packing with graphite packing
- ▶ **Drive type:** Electric actuator
- ▶ **Control function and/or Safety function:** Discharging wet, saturated and superheated steam when boiler starts, level regulation of start-up vessel
- ▶ **Highlights:** Leakage rate A, inner parts inserted, control and sealing edge separated, extremely hard-wearing materials

# Feedwater recirculation control valve

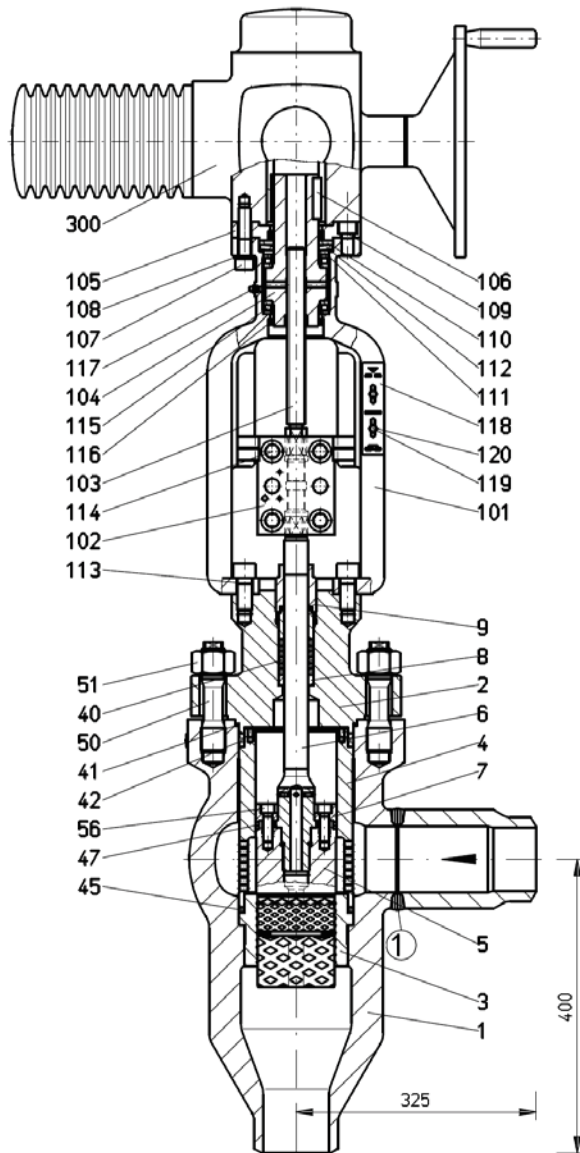

- ▶ **Application:** Gas and steam power plants, steam power plants, nuclear power plants
- ▶ **Product:** Recirculation control valve
- ▶ **Design:** Angular form
- ▶ **Housing material:** Forged steel
- ▶ **Pipe connection:** Weld ends
- ▶ **Valve cone type:** Multi-stage labyrinth plug
- ▶ **Valve seat seal:** Metallic
- ▶ **Spindle seal:** Gland packing with graphite seal
- ▶ **Drive type:** Electric actuator
- ▶ **Control function and/or Safety function:** Pump protection
- ▶ **Highlights:** Leakage rate A, inner parts inserted, up to 500 bar dp

# Water injection valve

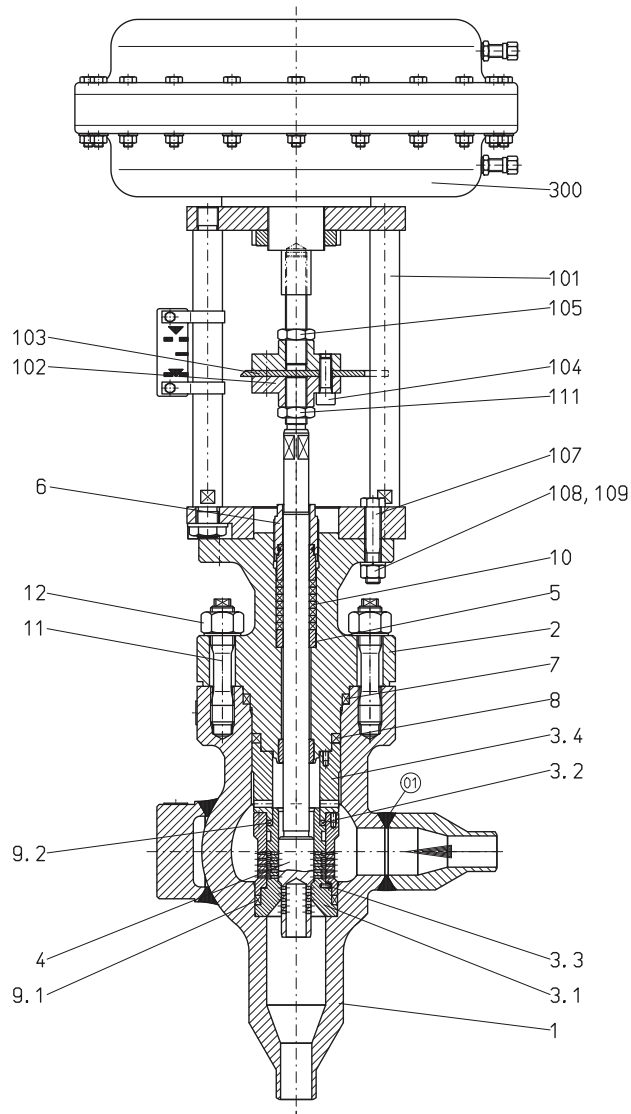

- ▶ **Application:** Gas and steam power plants, steam power plants, nuclear power plants
- ▶ **Product:** Water injection valve
- ▶ **Design:** Angular form
- ▶ **Housing material:** Forged steel
- ▶ **Pipe connection:** Weld ends
- ▶ **Valve cone type:** Multi-stage throttle system consisting of perforated cage and perforated throttle stages
- ▶ **Valve seat seal:** Metallic
- ▶ **Spindle seal:** Gland packing with graphite packing
- ▶ **Drive type:** Pneumatic actuator
- ▶ **Control function and/or Safety function:** Regulation of steam temperature
- ▶ **Highlights:** Leakage rate A, inner parts inserted, multi-stage perforated throttle stages, extremely wear-resistant materials



# Water injection valve

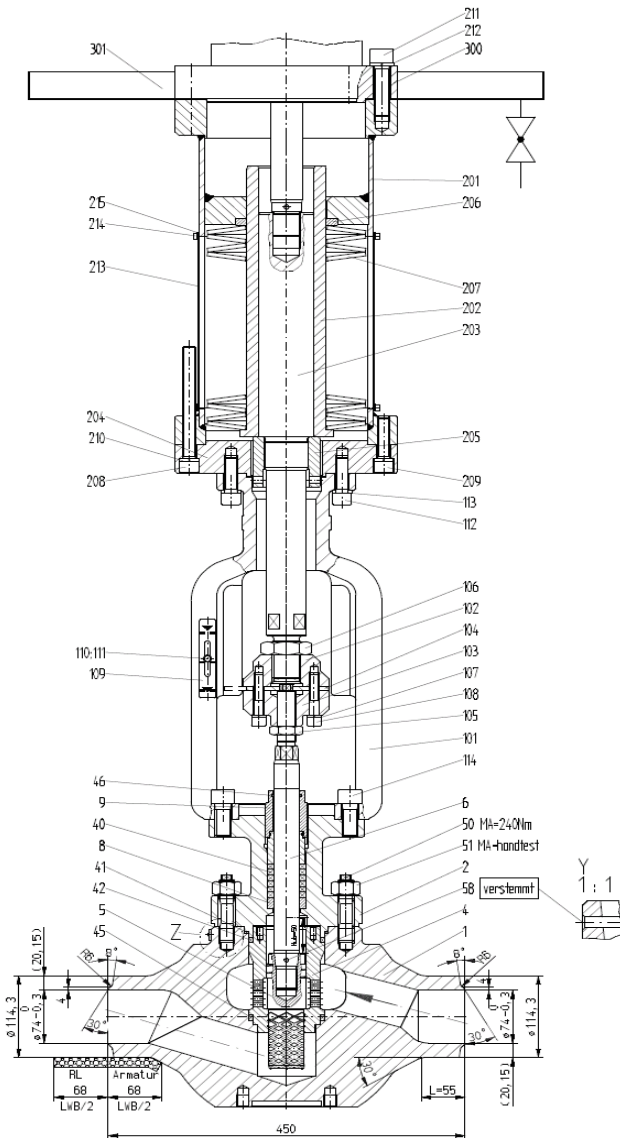

- ▶ **Application:** Gas and steam power plants, steam power plants, nuclear power plants
- ▶ **Product:** Water injection valve
- ▶ **Design:** Straight
- ▶ **Housing material:** Forged steel
- ▶ **Pipe connection:** Weld ends
- ▶ **Valve cone type:** Multi-stage throttle system consisting of perforated cage and labyrinth cone
- ▶ **Valve seat seal:** Metallic
- ▶ **Spindle seal:** Gland packing with graphite packing
- ▶ **Drive type:** Hydraulic actuator
- ▶ **Control function and/or Safety function:** Regulation of steam temperature
- ▶ **Highlights:** Leakage rate A, inner parts inserted, multi-stage, extremely durable materials, labyrinth plug

# Blow-off control valve

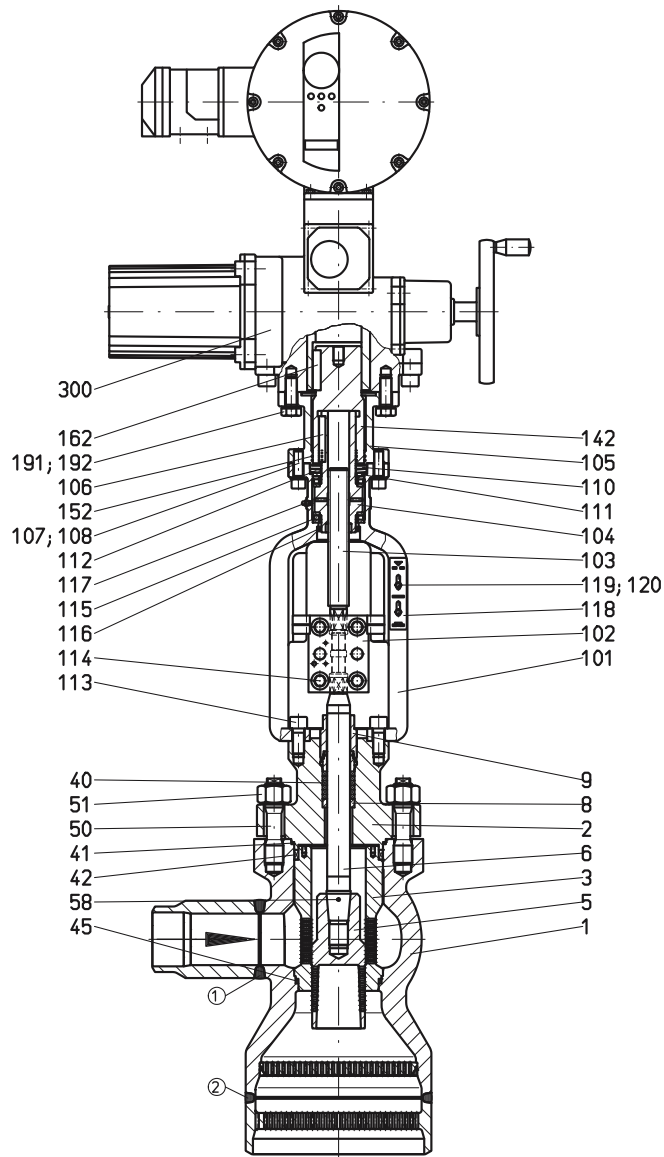

- ▶ **Application:** Gas and steam power plants, steam power plants, nuclear power plants
- ▶ **Product:** Blow-off control valve
- ▶ **Design:** Angular form
- ▶ **Housing material:** Forged steel
- ▶ **Pipe connection:** Weld ends
- ▶ **Valve cone type:** Multi-stage throttle system, perforated discs
- ▶ **Valve seat seal:** Metallic
- ▶ **Spindle seal:** Gland packing with graphite packing
- ▶ **Drive type:** Electric actuator
- ▶ **Control function and/or Safety function:** Blowing off excessive steam before safety valve triggers
- ▶ **Highlights:** Leakage rate A, inner parts inserted, robust design

# Condensate level control valve

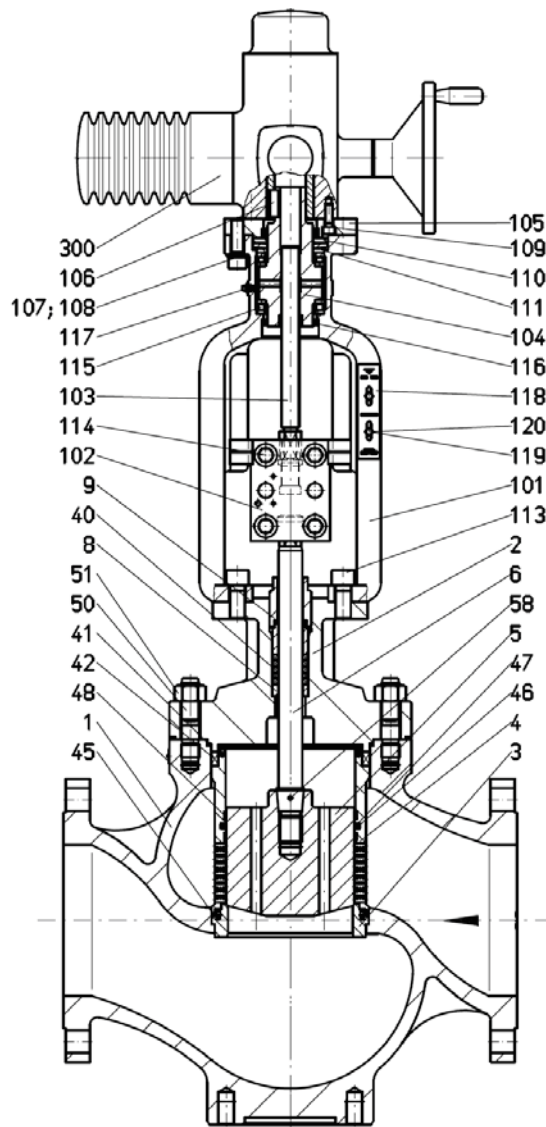

- ▶ **Application:** Gas and steam power plants, steam power plants, nuclear power plants
- ▶ **Product:** Condensate control valve
- ▶ **Design:** Straight
- ▶ **Housing material:** Cast housing
- ▶ **Pipe connection:** Flanges
- ▶ **Valve cone type:** Perforated cage, balanced (< 230° C)
- ▶ **Valve seat seal:** Metallic
- ▶ **Spindle seal:** Gland packing with graphite seal
- ▶ **Drive type:** Electric actuator
- ▶ **Control function and/or Safety function:** Level regulation
- ▶ **Highlights:** Leakage rate A, inner parts inserted

# Superheater safety valve

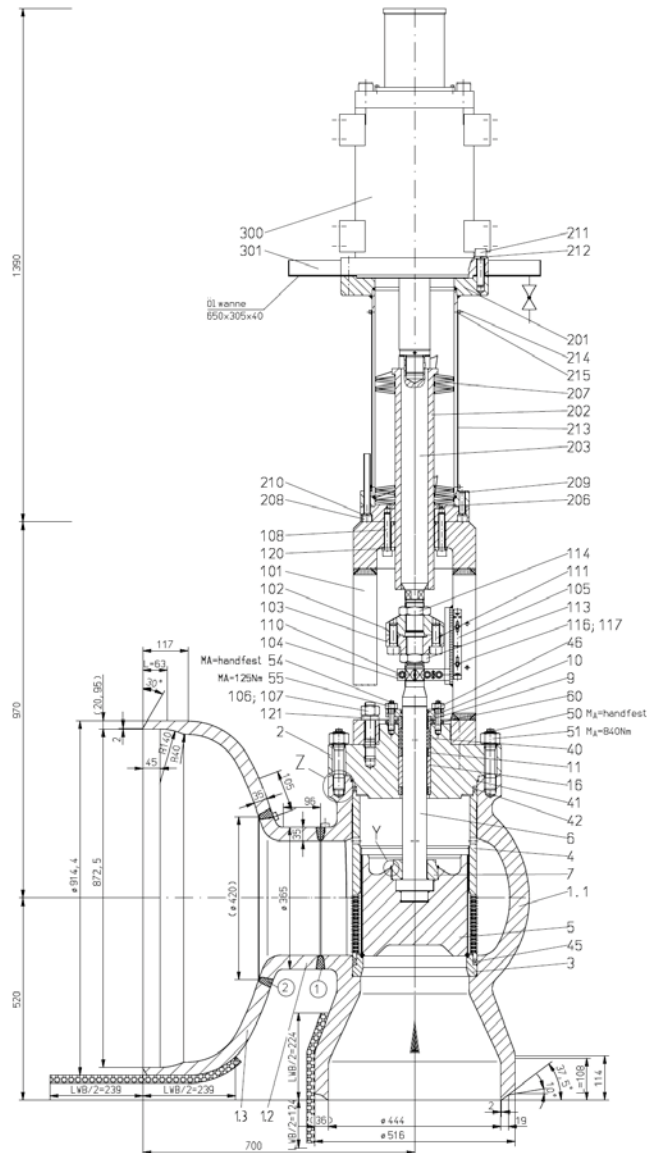

- ▶ **Application:** Gas and steam power plants, steam power plants, nuclear power plants
  
- ▶ **Product:** Superheater safety valve
  
- ▶ **Design:** Angular form
  
- ▶ **Housing material:** Forged
  
- ▶ **Pipe connection:** Weld ends
  
- ▶ **Valve cone type:** Piston
  
- ▶ **Valve seat seal:** Metallic
  
- ▶ **Spindle seal:** Gland packing with graphite packing
  
- ▶ **Drive type:** Hydraulic actuator with disc spring stack
  
- ▶ **Control function and/or Safety function:** Pressure protection acc. to TRD 421 via steam test device, controlled safety valve
  
- ▶ **Highlights:** Leakage rate A, inner parts inserted



# Turbine extraction valve, steam extraction valve

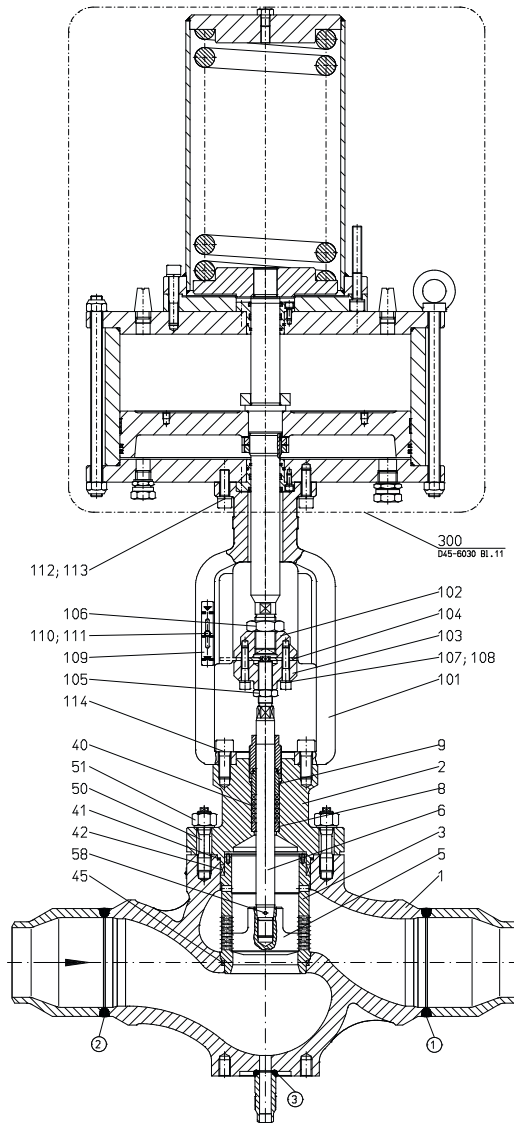

- ▶ **Application:** Gas and steam power plants, steam power plants, nuclear power plants
- ▶ **Product:** Turbine extraction valve, steam extraction valve
- ▶ **Design:** Straight
- ▶ **Housing material:** Cast steel
- ▶ **Pipe connection:** Weld ends
- ▶ **Valve plug type:** Perforated cage
- ▶ **Valve seat seal:** Metallic
- ▶ **Spindle seal:** Gland packing with graphite packing
- ▶ **Drive type:** Pneumatic piston drive
- ▶ **Control function and/or Safety function:** Extraction pressure regulation, can be combined with safety function close < 0.5 s
- ▶ **Highlights:** Leakage rate A, inner parts inserted

# High pressure quick-action valve

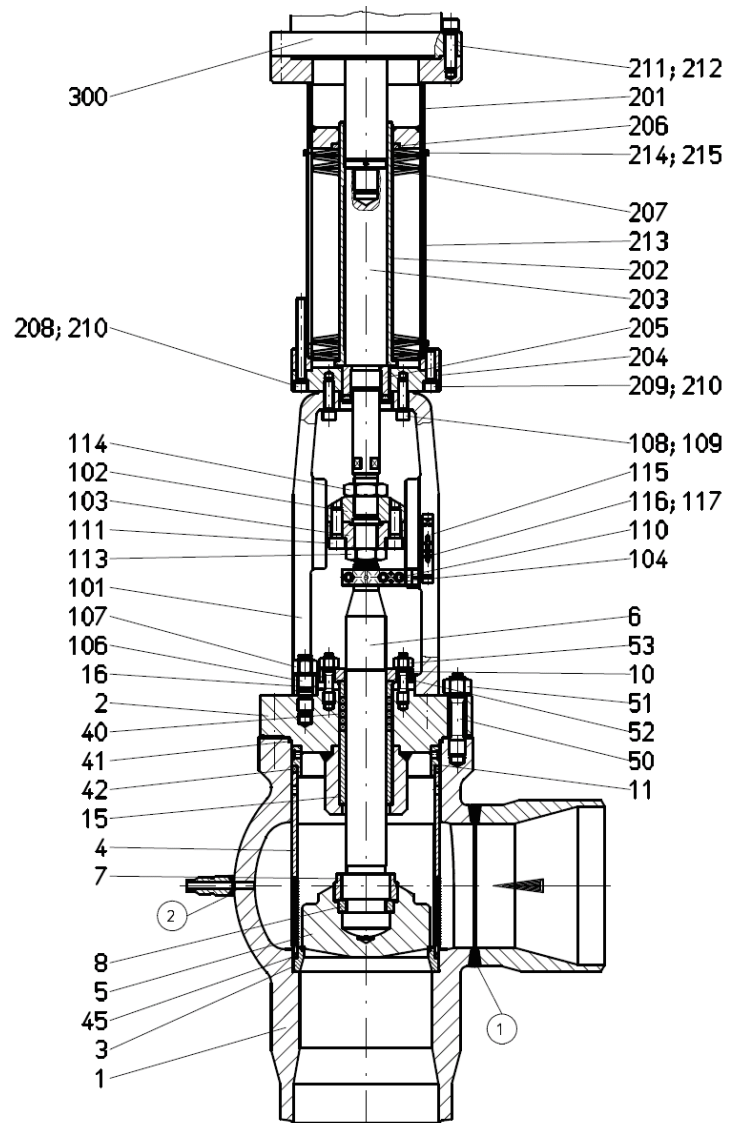

- ▶ **Application:** Gas and steam power plants, steam power plants, nuclear power plants
- ▶ **Product:** Steam quick-action stop valve
- ▶ **Design:** Angular form
- ▶ **Housing material:** Forged steel
- ▶ **Pipe connection:** Weld ends
- ▶ **Valve plug type:** Open/close plug (suspended)
- ▶ **Valve seat seal:** Metallic
- ▶ **Spindle seal:** Gland packing with graphite packing
- ▶ **Drive type:** Hydraulic actuator
- ▶ **Control function and/or Safety function:** Closing in < 0.2 sec.
- ▶ **Highlights:** Leakage rate A, inner parts inserted, built-in strainer

# High pressure quick-action valve

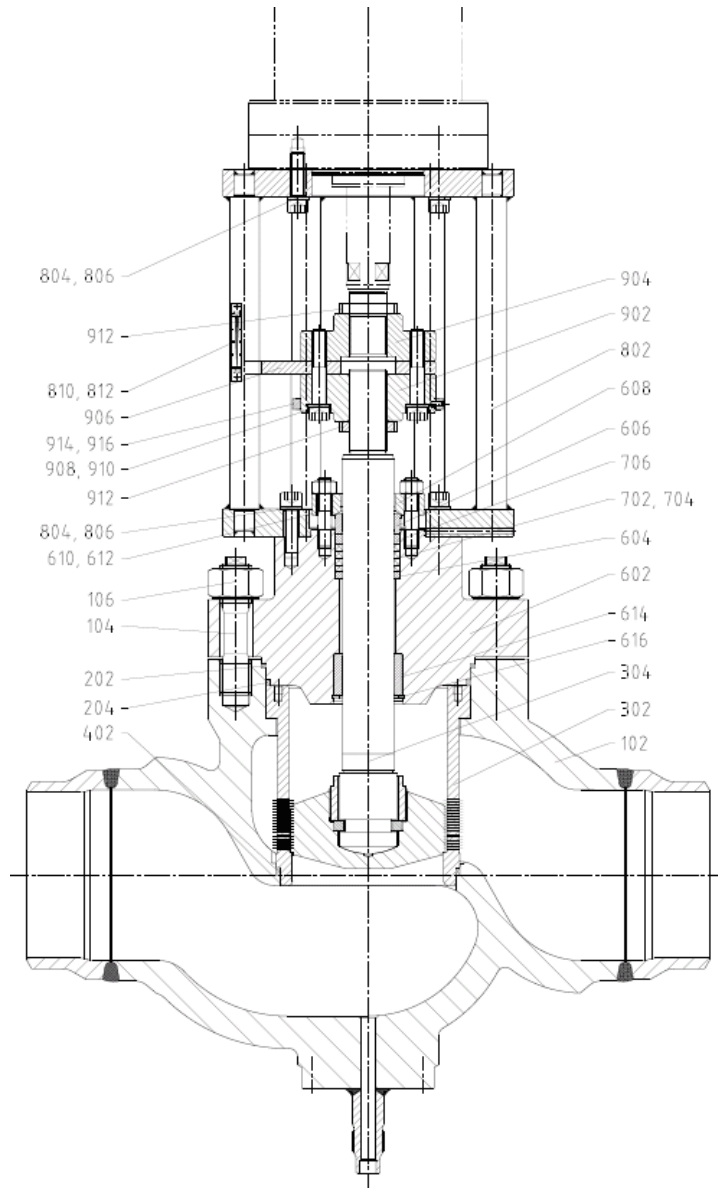

- ▶ **Application:** Bypass station
- ▶ **Product:** High pressure quick-action valve
- ▶ **Design:** Straight
- ▶ **Housing material:** Cast steel
- ▶ **Pipe connection:** Weld ends
- ▶ **Valve plug type:** Shut-off cone
- ▶ **Valve seat seal:** Metallic
- ▶ **Spindle seal:** Gland packing with graphite packing
- ▶ **Drive type:** Hydraulic actuator
- ▶ **Control function and/or Safety function:** Quick-acting if turbine trips
- ▶ **Highlights:** Leakage rate A, inner parts inserted, built-in strainer

# Steam conversion stations

## ▶ Atomising steam desuperheater, downstream

- + short vaporisation distance
- + inner parts protected
- + minimum flow rate of 5% achievable
- + cooling near to saturated steam temperature
- + up to 30 % water / steam ratio
- + no additional atomising steam required in combination with DUV
- high complexity for large volumes of injected water
- investment intensive



## ▶ Integrated injection

- + injection into areas with high flow speeds for best mixing
- + precise and rapid regulation
- + cost-effectiveness
- high stress on internal parts
- limited to max. water volume of 10t/h
- max. 15-20 % water / steam ratio



## ▶ Downstream lance injection

- + no contact with internal parts
- + cost-effective alternative for condenser applications
- + lower manufacturing costs than 1.
- $\Delta T_{cool}$  must be  $>50^{\circ}C$
- load incidences below 20 % critical
- temperature control  $\pm 10K$  tolerance

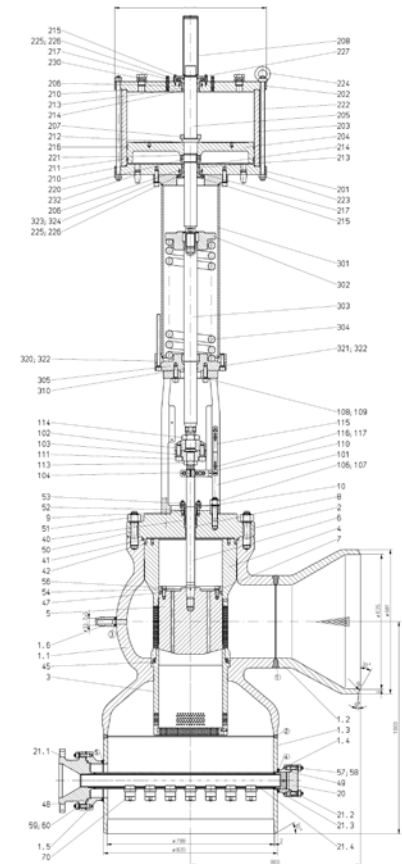



# High pressure bypass station

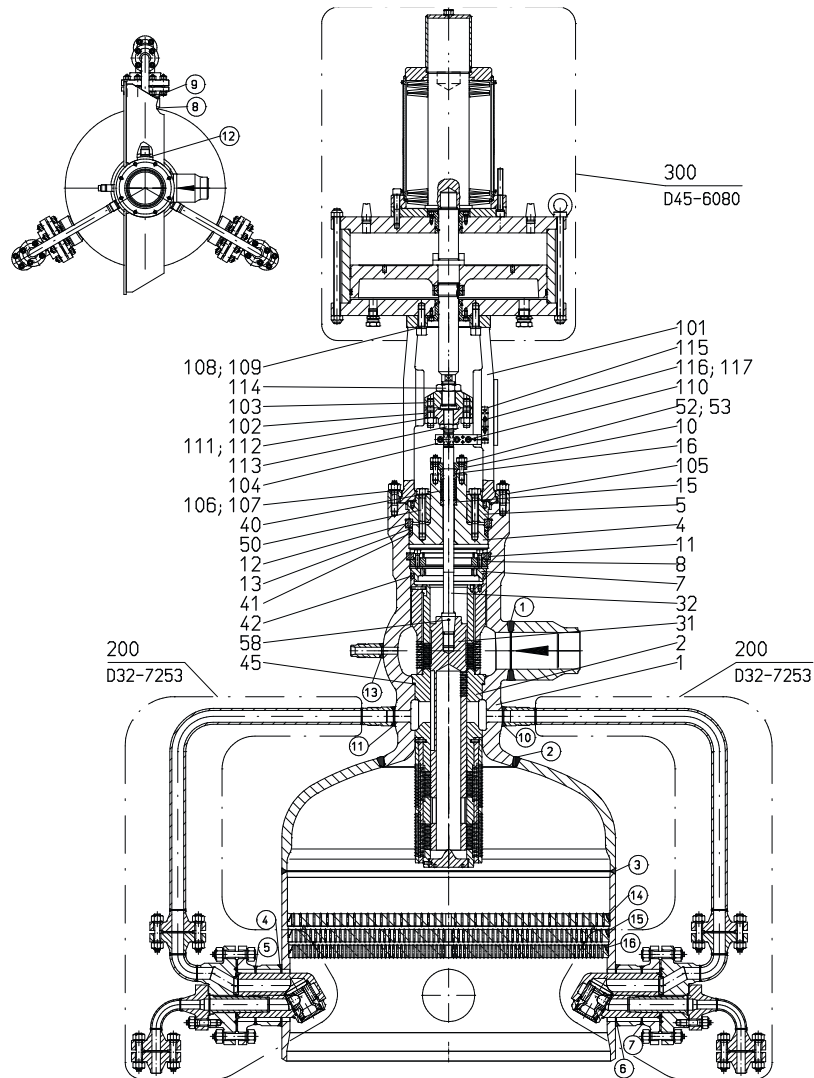

- ▶ **Application:** Gas and steam power plants, steam power plants, nuclear power plants
  
- ▶ **Product:** Turbine bypass station with built-in atomising steam extraction and 2 to 3 desuperheaters
  
- ▶ **Design:** Angular form
  
- ▶ **Housing material:** Forged steel
  
- ▶ **Pipe connection:** Weld ends
  
- ▶ **Valve plug type:** Multi-stage throttle system consisting of seat cage, perforated plug and perforated cages
  
- ▶ **Valve seat seal:** Metallic
  
- ▶ **Spindle seal:** Gland packing with graphite packing
  
- ▶ **Drive type:** Pneumatic actuator
  
- ▶ **Control function and/or Safety function:**
  - a) steam extraction on boiler start-up
  - b) steam extraction if turbine trips
  - c) downstream pressure regulation
  
- ▶ **Highlights:** Leakage rate A, inner parts inserted, fully regulated perforated throttle stages, internal atomising steam extraction



# LP bypass station complete

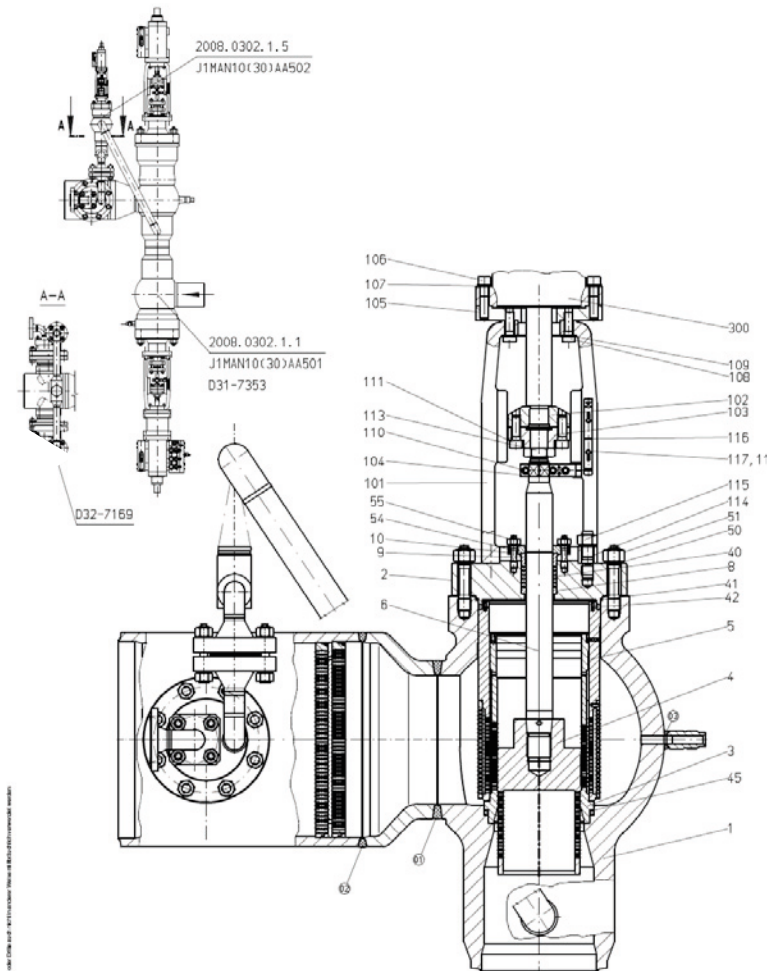

- ▶ **Application:** Gas and steam power plants, steam power plants, nuclear power plants
  
- ▶ **Product:** High-pressure bypass station (HPB) with atomising steam extraction before pressure reduction, with atomising steam shut-off valve, with 1 desuperheater, with welded steam quick-action stop valve
  
- ▶ **Design:** Angular form
  
- ▶ **Housing material:** Forged steel
  
- ▶ **Pipe connection:** Weld ends
  
- ▶ **Valve plug type:** Multi-stage throttle system consisting of perforated plug, 3 perforated cages and 2 perforated discs
  
- ▶ **Valve seat seal:** Metallic
  
- ▶ **Spindle seal:** Gland packing with graphite packing
  
- ▶ **Drive type:** Hydraulic actuator
  
- ▶ **Control function and/or Safety function:**
  - a) steam extraction on boiler start-up
  - b) steam extraction if turbine trips
  - c) downstream pressure regulation
  
- ▶ **Highlights:** Leakage rate A, inner parts inserted, "low noise" design, fully regulated perforated throttle stages, injection supported by atomising steam

# Atomising steam-assisted desuperheater

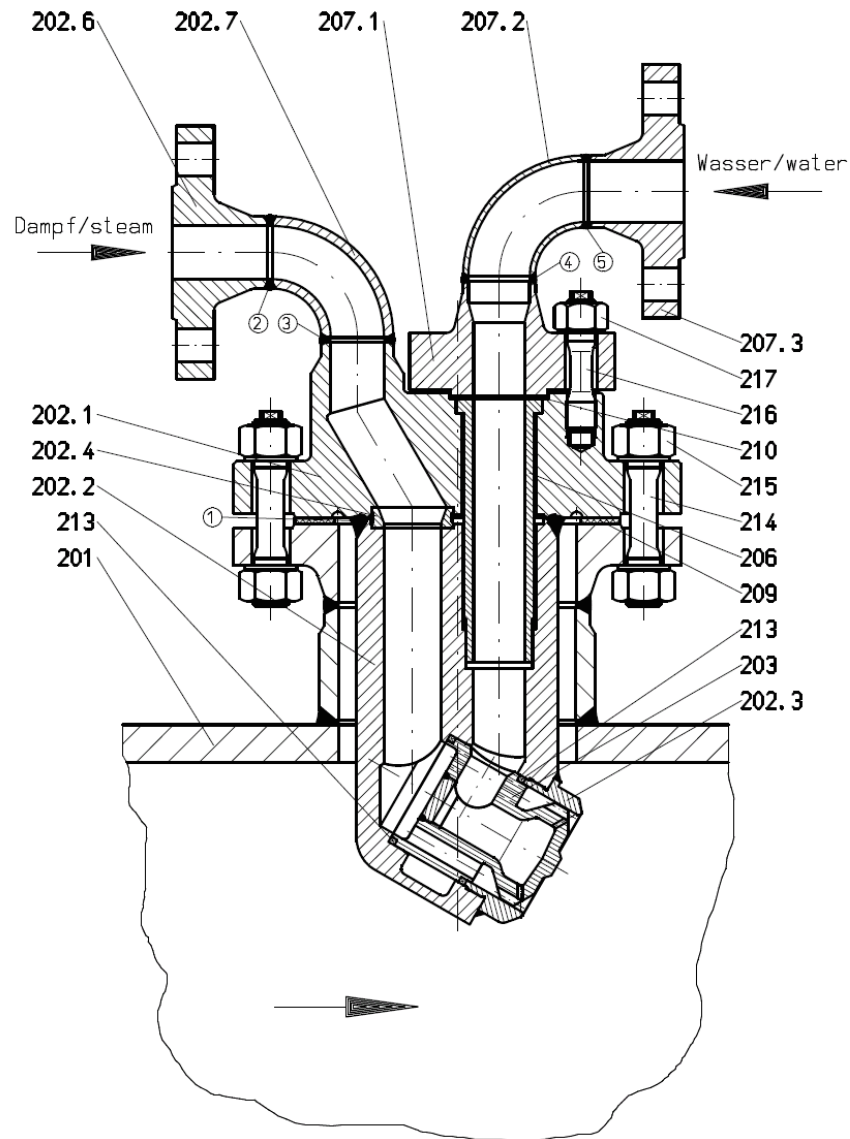

- ▶ **Application:** Gas and steam power plants, steam power plants, nuclear power plants
- ▶ **Product:** Atomising steam-assisted desuperheater
- ▶ **Design:** Straight
- ▶ **Housing material:** Forged steel
- ▶ **Pipe connection:** Flanges
- ▶ **Valve plug type:** Atomising steam desuperheater
- ▶ **Valve seat seal:** –
- ▶ **Spindle seal:** –
- ▶ **Drive type:** –
- ▶ **Control function and/or Safety function:** Regulation of steam temperature
- ▶ **Highlights:** Precise temperature control to minimum of 3K above saturated steam temperature



# High pressure bypass station

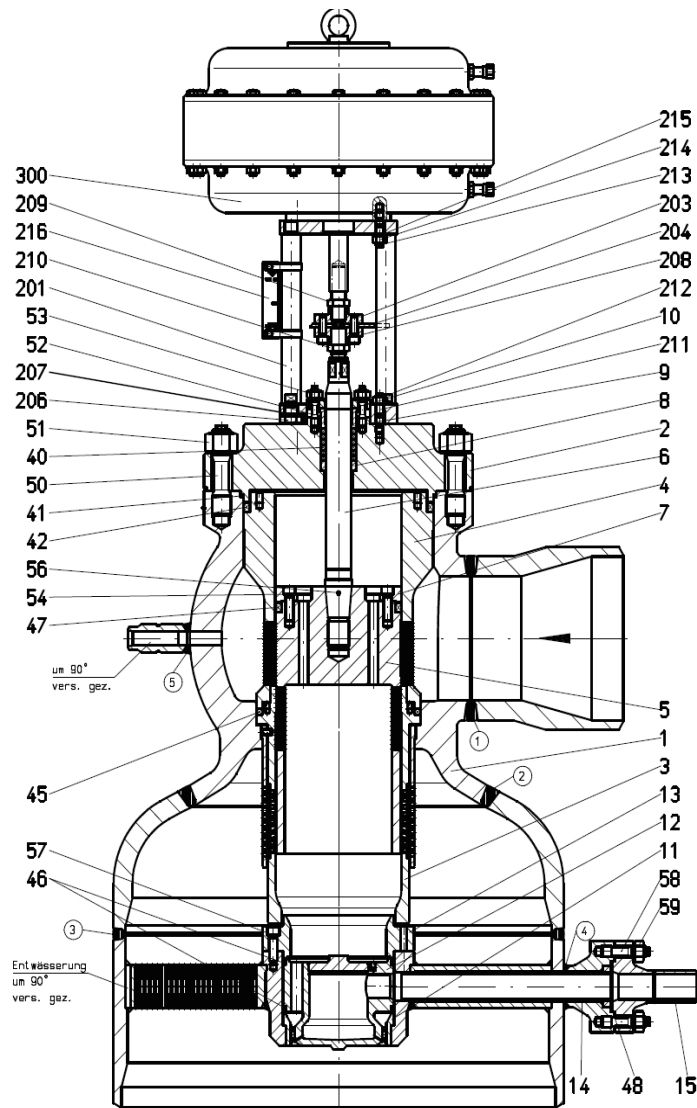

- ▶ **Application:** Gas and steam power plants, steam power plants, nuclear power plants
- ▶ **Product:** Turbine bypass station with built-in atomising steam extraction and in-built single desuperheater
- ▶ **Design:** Angular form
- ▶ **Housing material:** Cast steel
- ▶ **Pipe connection:** Weld ends
- ▶ **Valve plug type:** Multi-stage throttle system consisting of seat cage, perforated plug and perforated cages
- ▶ **Valve seat seal:** Metallic
- ▶ **Spindle seal:** Gland packing with graphite packing
- ▶ **Drive type:** Pneumatic actuator
- ▶ **Control function and/or Safety function:**
  - a) steam extraction on boiler start-up
  - b) steam extraction if turbine trips
  - c) downstream pressure regulation
- ▶ **Highlights:** Leakage rate A, inner parts inserted, fully regulated perforated throttle stages, internal atomising steam extraction

# Low-pressure bypass station

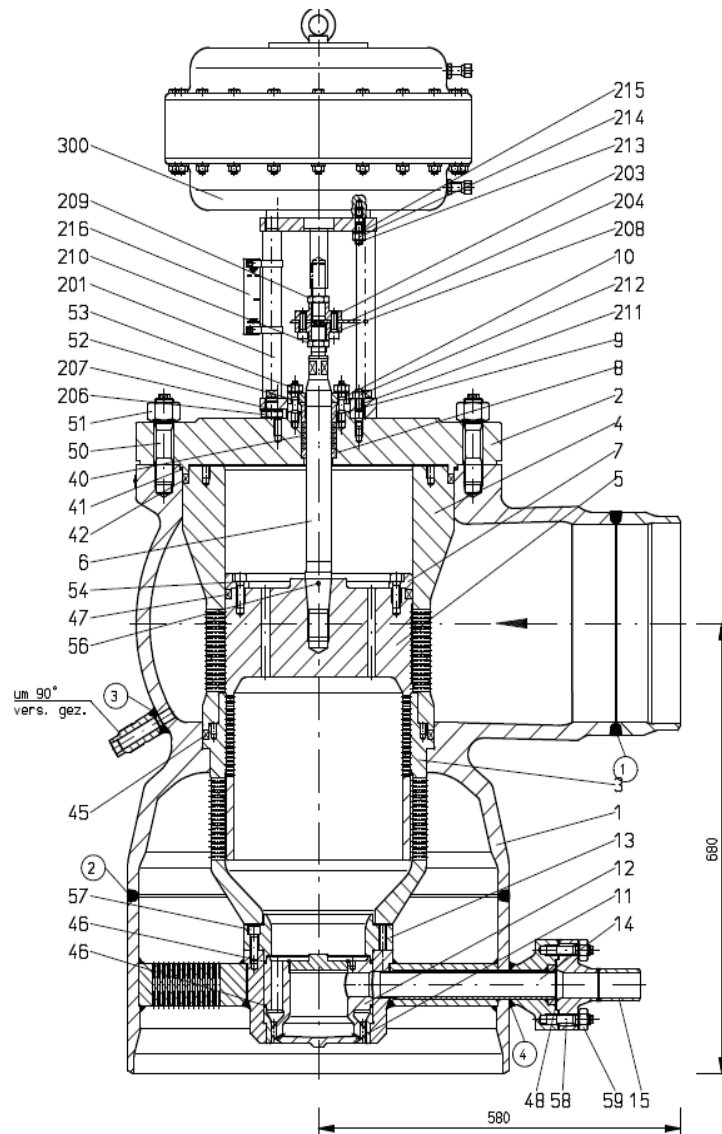

- ▶ **Application:** Gas and steam power plants, steam power plants, nuclear power plants
  
- ▶ **Product:** Turbine bypass station with built-in atomising steam extraction and 2 to 3 desuperheaters
  
- ▶ **Design:** Angular form
  
- ▶ **Housing material:** Cast steel
  
- ▶ **Pipe connection:** Weld ends
  
- ▶ **Valve plug type:** Multi-stage throttle system consisting of seat cage, perforated plug and perforated cages
  
- ▶ **Valve seat seal:** Metallic
  
- ▶ **Spindle seal:** Gland packing with graphite packing
  
- ▶ **Drive type:** Pneumatic actuator
  
- ▶ **Control function and/or Safety function:**
  - a) steam extraction on boiler start-up
  - b) steam extraction if turbine trips
  - c) downstream pressure regulation
  
- ▶ **Highlights:** Leakage rate A, inner parts inserted, fully regulated perforated throttle stages, internal atomising steam extraction

# Steam conversion valve

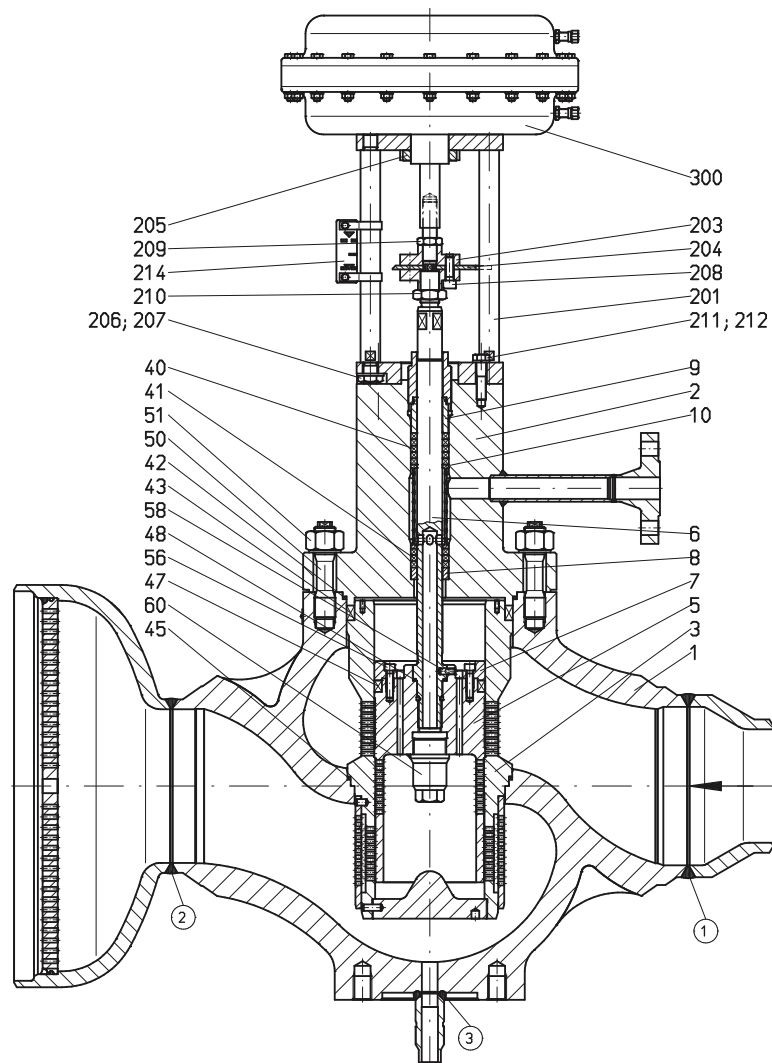

- ▶ **Application:** Gas and steam power plants, steam power plants, nuclear power plants
- ▶ **Product:** Steam conversion valve
- ▶ **Design:** Straight
- ▶ **Housing material:** Cast steel
- ▶ **Pipe connection:** Flanges
- ▶ **Valve plug type:** Multi-stage throttle system consisting of perforated cage and perforated plug, internal water injection
- ▶ **Valve seat seal:** Metallic
- ▶ **Spindle seal:** Gland packing with graphite packing
- ▶ **Drive type:** Pneumatic actuator
- ▶ **Control function and/or Safety function:** Regulation of steam parameters in steam networks
- ▶ **Highlights:** Easily replaceable inner parts, perfect water atomisation, tight-sealing

# High pressure bypass station with pressurised water desuperheater

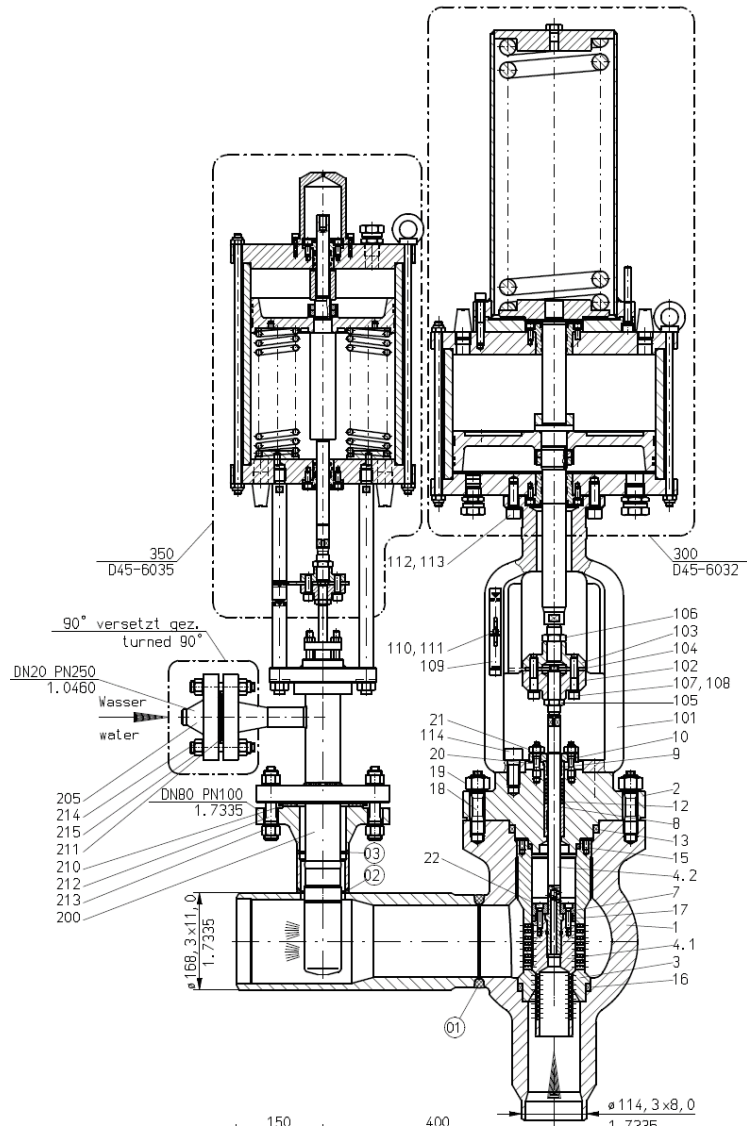

- ▶ **Application:** Gas and steam power plants, steam power plants, nuclear power plants
- ▶ **Product:** High-pressure bypass station (HPB) with pressurised water desuperheater
- ▶ **Design:** Angular form
- ▶ **Housing material:** Forged steel
- ▶ **Pipe connection:** Weld ends
- ▶ **Valve plug type:** Multi-stage throttle system consisting of perforated plug and seat cage
- ▶ **Valve seat seal:** Metallic
- ▶ **Spindle seal:** Gland packing with graphite packing
- ▶ **Drive type:** Pneumatic actuator
- ▶ **Control function and/or Safety function:**
  - a) steam extraction on boiler start-up
  - b) steam extraction if turbine trips
  - c) downstream pressure regulation
- ▶ **Highlights:** Leakage rate A, inner parts inserted, maintenance-friendly



# Products for the oil and gas industry



# Scheme: Oil and gas compressor

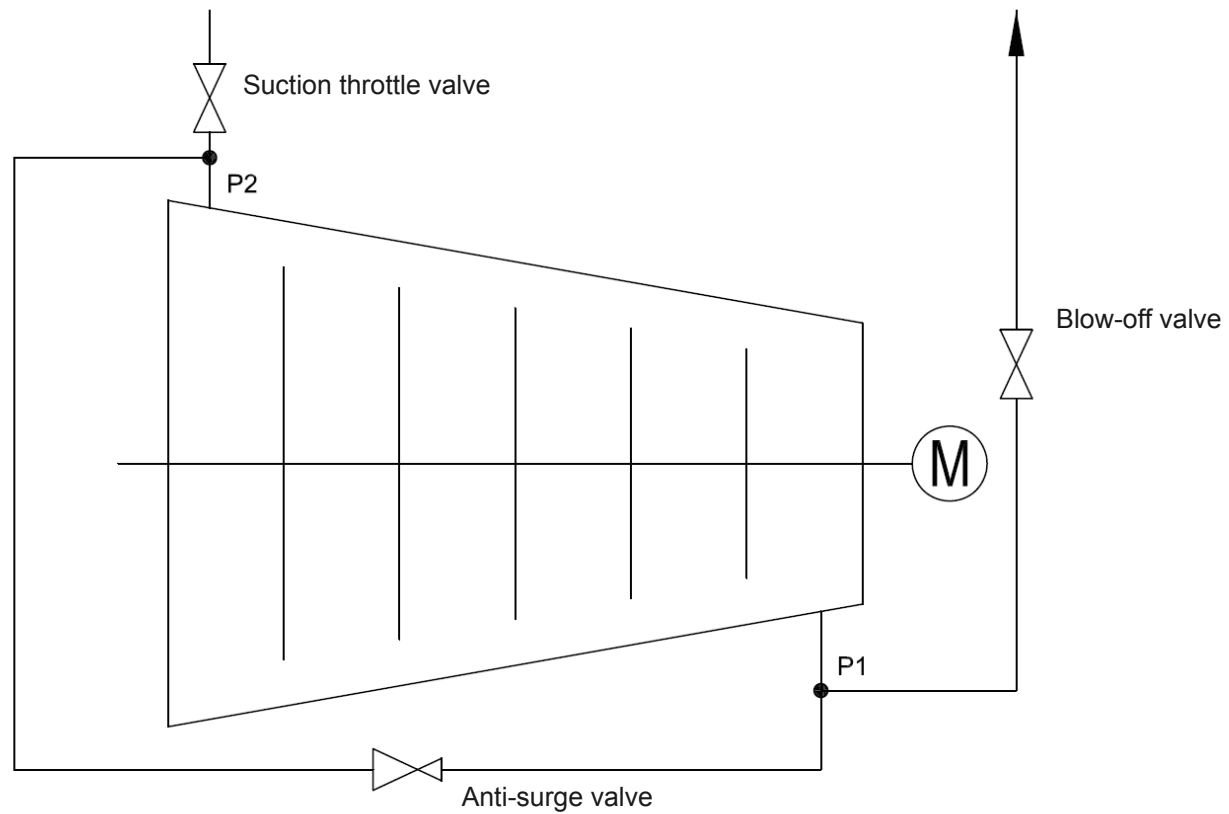

# Valve for oxygen, nitrogen

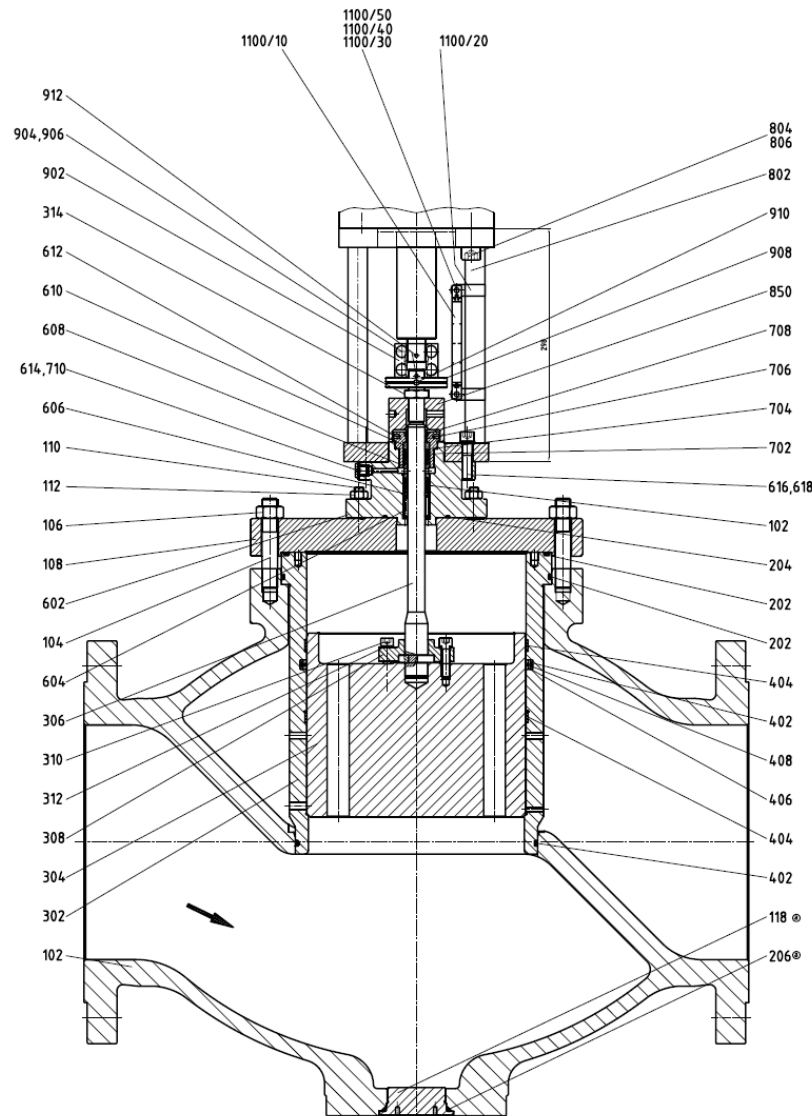

- ▶ **Application:** Gas separation systems, gas preparation systems
- ▶ **Product:** Valve for air separation
- ▶ **Design:** Straight
- ▶ **Housing material:** Bronze (copper-tin alloy)
- ▶ **Pipe connection:** Flanges
- ▶ **Valve plug type:** Perforated cage
- ▶ **Valve seat seal:** Metallic
- ▶ **Spindle seal:** Gland packing with V sleeves
- ▶ **Drive type:** Pneumatic actuator
- ▶ **Control function and/or Safety function:** Valve for air separation
- ▶ **Highlights:** Free of oil or grease for applications with oxygen, seals with BAM certification, balanced, leakage rate A



# Storage and discharge valve

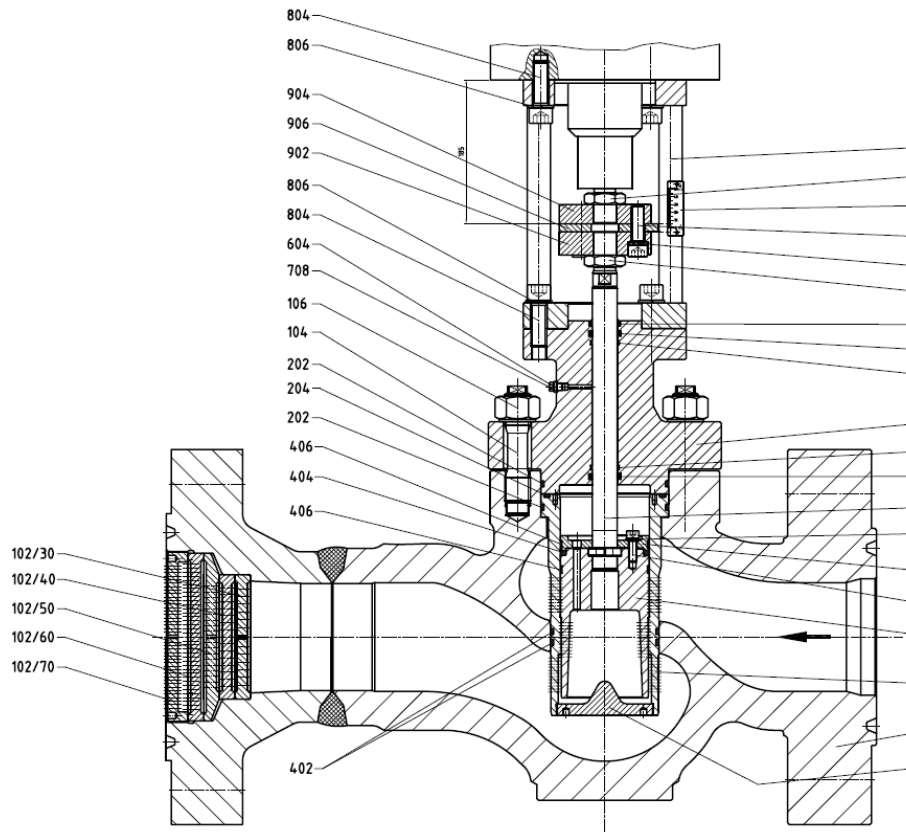

- ▶ **Application:** Gas storage facility, caverns
  
- ▶ **Product:** Storage and discharge valve for gas cavern
  
- ▶ **Design:** Straight
  
- ▶ **Housing material:** Cast steel
  
- ▶ **Pipe connection:** Flanges with ring joint nut
  
- ▶ **Valve plug type:** Multi-stage throttle system consisting of 2 seat cages, perforated plug and 6 perforated discs
  
- ▶ **Valve seat seal:** Metallic
  
- ▶ **Spindle seal:** Soft sleeve
  
- ▶ **Drive type:** Hydraulic actuator
  
- ▶ **Control function and/or Safety function:** Summer: storage in gas storage facility, Winter: discharge from gas storage facility
  
- ▶ **Highlights:** Extreme diff. pressures, balanced



# Gas pressure control valve and pipeline valve

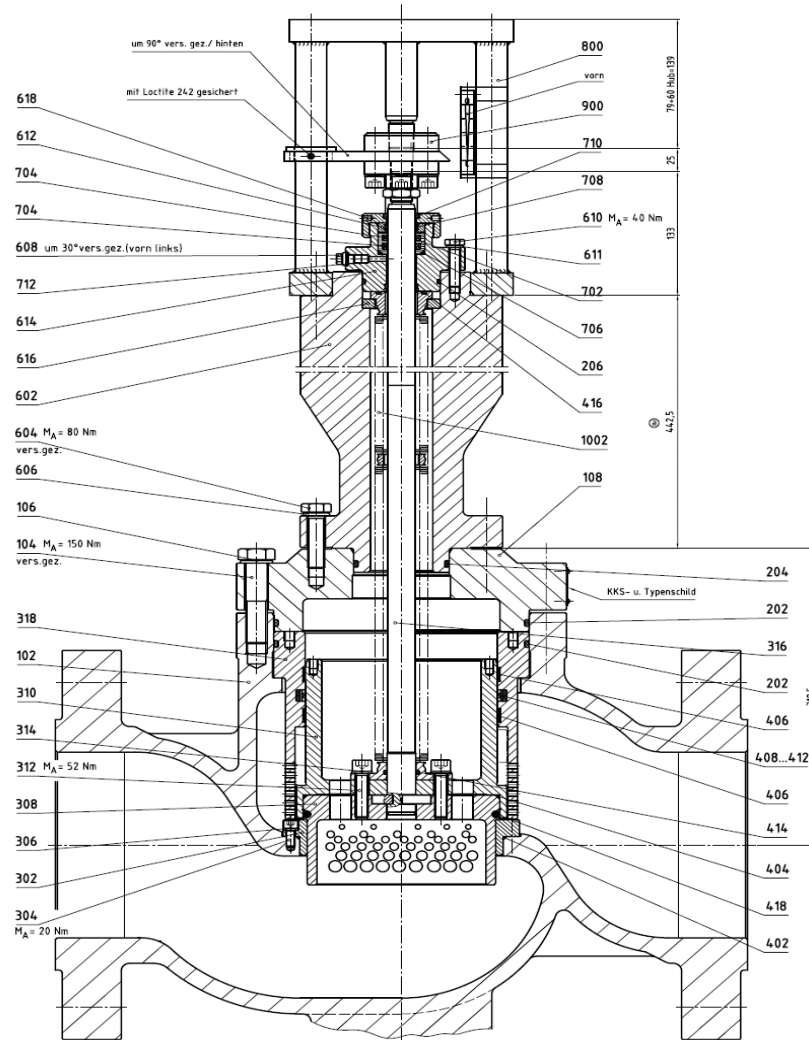

- ▶ **Application:** Gas transfer stations  
Gas distribution stations
- ▶ **Product:** Gas pressure regulator for gas turbines  
Gas pressure regulator for gas grids
- ▶ **Design:** Straight
- ▶ **Housing material:** Cast steel
- ▶ **Pipe connection:** Flanges
- ▶ **Valve plug type:** Multi-stage throttle system consisting of perforated cage and perforated plug
- ▶ **Valve seat seal:** Soft sealing
- ▶ **Spindle seal:** Bellows
- ▶ **Drive type:** Hydraulic actuator
- ▶ **Control function and/or Safety function:** Gas pressure regulator for controlling burner  
Gas pressure regulator for gas grids
- ▶ **Highlights:** Low noise, leakage rate A

# Anti-surge valve

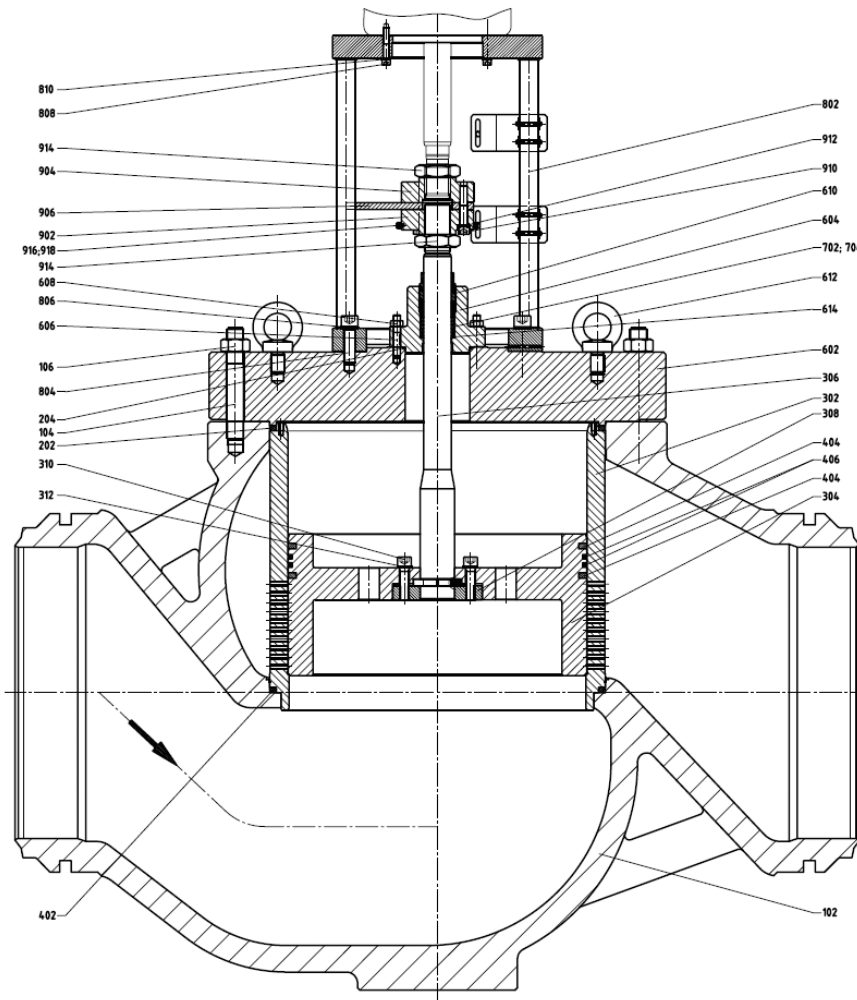

- ▶ **Application:** Gas compressor, compressors
- ▶ **Product:** Anti-surge valve
- ▶ **Design:** Straight
- ▶ **Housing material:** Cast steel
- ▶ **Pipe connection:** Weld ends
- ▶ **Valve plug type:** Perforated cage
- ▶ **Valve seat seal:** Metallic
- ▶ **Spindle seal:** Gland packing with graphite packing
- ▶ **Drive type:** Hydraulic actuator
- ▶ **Control function and/or Safety function:** The valve controls the flow of gas on the suction side of the compressor before the compressor's surge line.
- ▶ **Highlights:** Fast-opening  $\leq 1s$ , cast iron design up to DN 750

# Blow-off valve

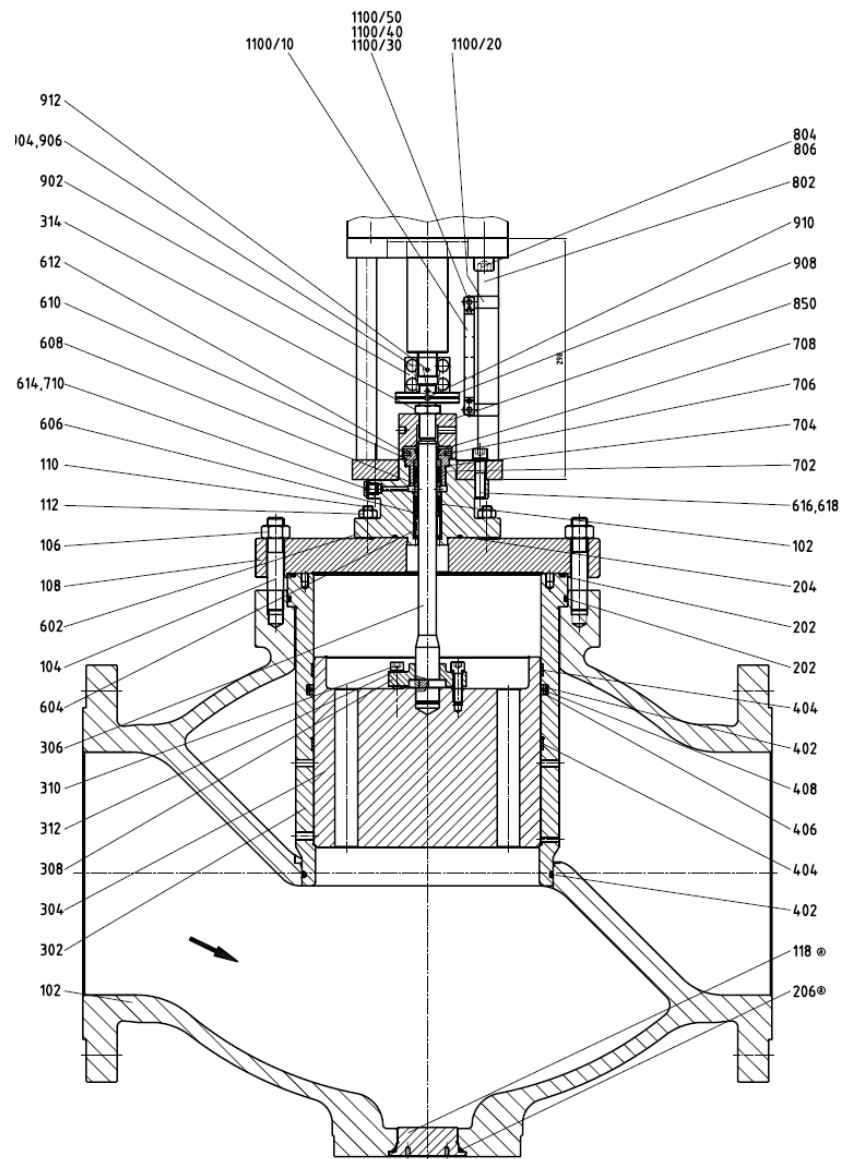

- ▶ **Application:** Gas compressor, compressors
- ▶ **Product:** Blow-off valve
- ▶ **Design:** Straight
- ▶ **Housing material:** Cast steel
- ▶ **Pipe connection:** Flanges
- ▶ **Valve plug type:** Perforated cage
- ▶ **Valve seat seal:** Metallic
- ▶ **Spindle seal:** Gland packing with V sleeves
- ▶ **Drive type:** Pneumatic actuator
- ▶ **Control function and/or Safety function:** The valve discharges the flow of gas above roof level before the compressor's surge line.
- ▶ **Highlights:** Fast-opening  $\leq 1s$ , cast iron design up to DN 700

# Suction throttle valve

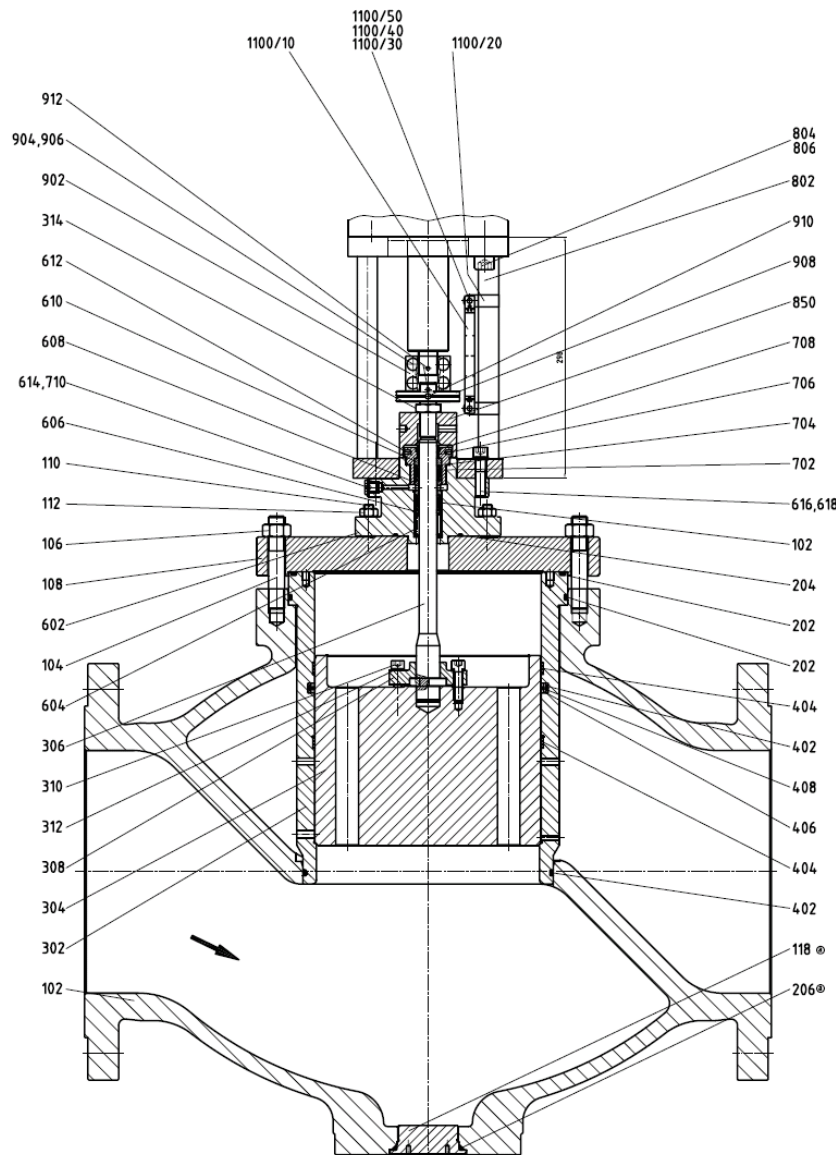

- ▶ **Application:** Gas compressor, compressors
- ▶ **Product:** Suction throttle valve
- ▶ **Design:** Straight
- ▶ **Housing material:** Cast steel
- ▶ **Pipe connection:** Flanges
- ▶ **Valve plug type:** Perforated cage
- ▶ **Valve seat seal:** Metallic
- ▶ **Spindle seal:** Gland packing with V sleeves
- ▶ **Drive type:** Pneumatic actuator
- ▶ **Control function and/or Safety function:** Controls the flow of gas to the compressor
- ▶ **Highlights:** Fast-opening  $\leq 1s$ , cast iron design up to DN 700



# Products for the iron and steel industry



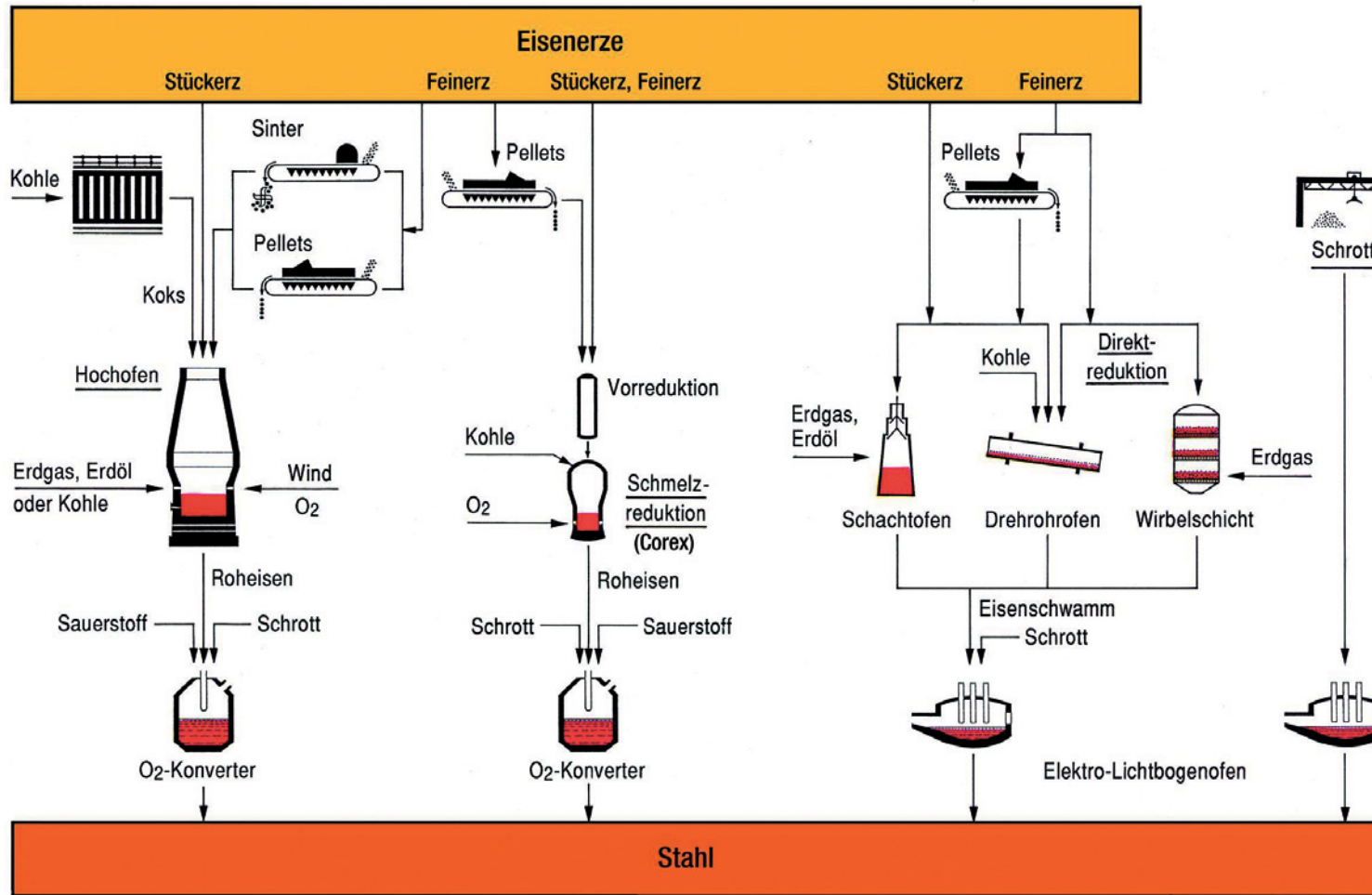



# Fresh air valve, cold wind valve

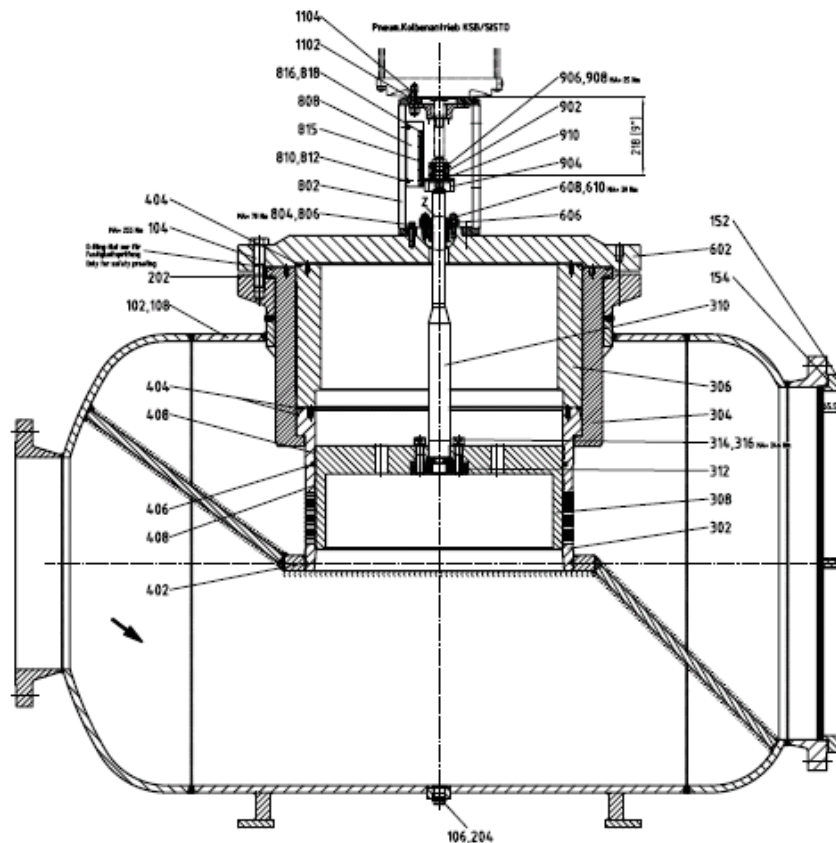

- ▶ **Application:** Fresh air furnace, cold wind furnace
- ▶ **Product:** Air control valve
- ▶ **Design:** Straight
- ▶ **Housing material:** Cast steel
- ▶ **Pipe connection:** Flanges
- ▶ **Valve plug type:** Perforated cage
- ▶ **Valve seat seal:** Metallic
- ▶ **Spindle seal:** Soft sleeve
- ▶ **Drive type:** Pneumatic actuator
- ▶ **Control function and/or Safety function:** Feeds the required volume of air to the furnace.
- ▶ **Highlights:** Nominal size up to DIN 1600

# Valve for O<sub>2</sub>, N<sub>2</sub> and Ar

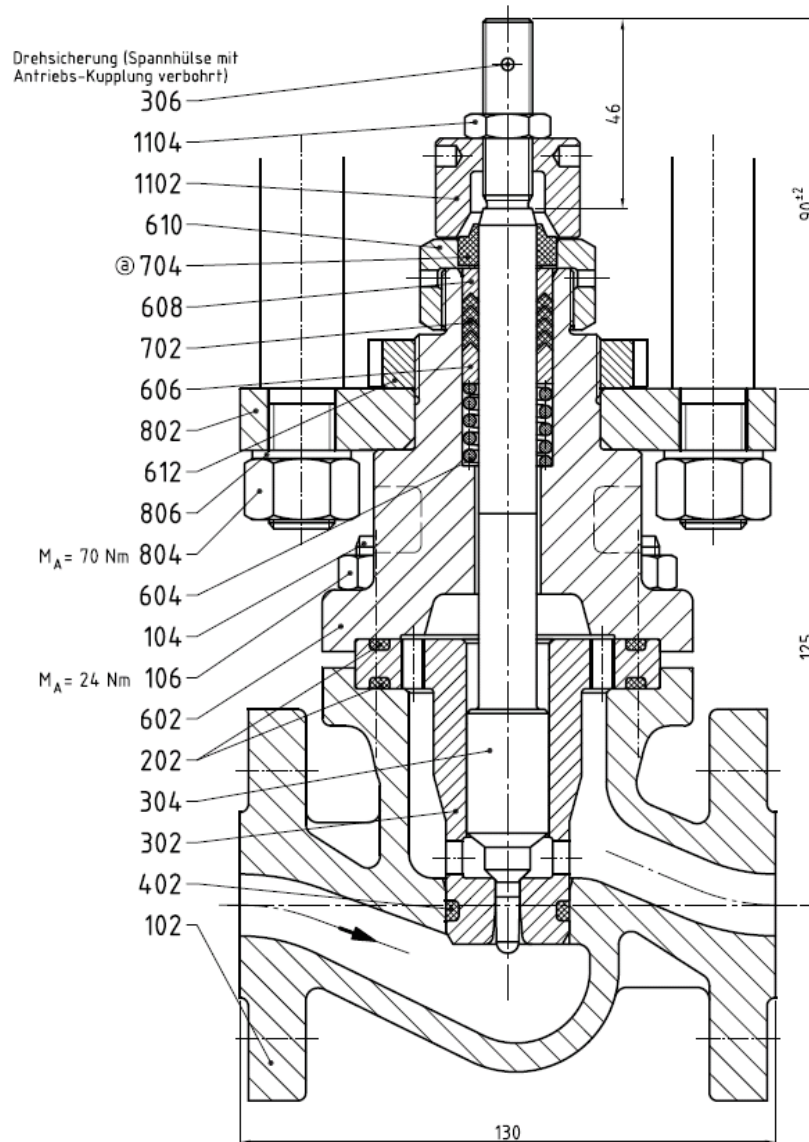

- ▶ **Application:** Steel production, Reduction plants
- ▶ **Product:** Oxygen valve, nitrogen valve, argon valve
- ▶ **Design:** Straight
- ▶ **Housing material:** Cast steel
- ▶ **Pipe connection:** Flanges
- ▶ **Valve plug type:** Parabolic/needle plug
- ▶ **Valve seat seal:** Metallic
- ▶ **Spindle seal:** Gland packing with V sleeves
- ▶ **Drive type:** Pneumatic and electrical actuator
- ▶ **Control function and/or Safety function:** Controls the substances required to produce steel
- ▶ **Highlights:** Precise control of minimal quantities



# Actuators

## ▶ Pneumatic own production



## ▶ Hydraulic own production



## ▶ Electrical according customer's request (Auma, Sipos, etc.)



KKS:7710L.BH30AA001

Antrieb

StpK 500  
 A = 1944 cm<sup>2</sup>  
 p<sub>max</sub>=6 bar  
 Antriebshub = 100 mm  
 Hubvolumen = 19,44 dm<sup>3</sup>  
 Luftmenge = 233,28 l/min.  
 bei min. Stellzeit = 5 sek.

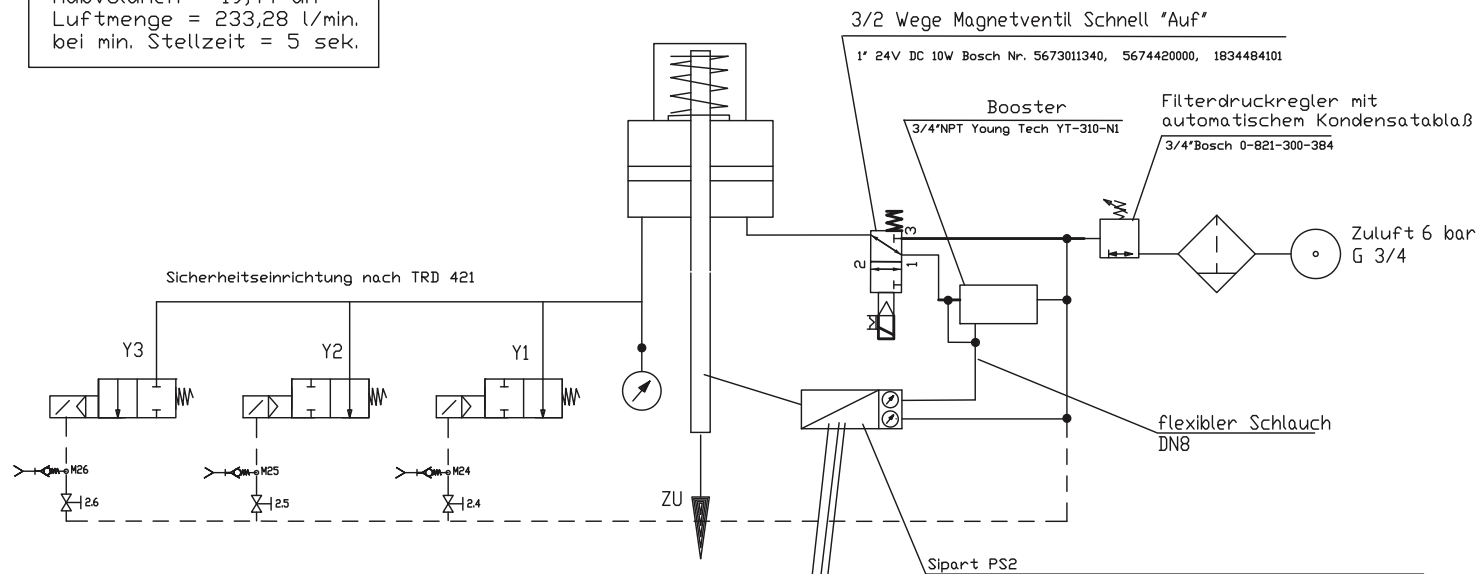

Binärer Eingang 9+10 <ZU>  
 Sollwert 4-20mA (+3/-8)  
 Istwert 4-20mA (+61/-62)

Sipart PS2  
 einfachwirkend, nicht Ex, Kunststoffgehäuse HART Nr. 6DR5110-ONG00-0AA0  
 Manometerblock: 0-6 bar einfachwirkend Nr. 6DR4004-1M  
 Hub 0-35 mm Nr. 6DR4004-8V  
 I/Y Modul Rückmeldung 4-20 mA Nr. 6DR4004-8J  
 Anlenkhebel: Hub 35 - 130mm Nr. 6DR4004-8L

Für diese Zeichnung behalten wir uns alle Rechte von Ihrer unsere vorherige Zustimmung darf sie weder vervielfältigt noch Dritten zugänglich gemacht werden, und sie darf durch den Empfänger oder Dritte auch nicht in anderer Weise nährsächlich verwendet werden.

HANNEMANN + PRUSS GmbH		Werkstoff:	APZ:	Maßstab 1:1	Gewicht
		1:--- 1:--- 1:---	3.1-	Halbzeug, Modell-Nr., Gesenk-Nr.	
Rev1	Booster NPT 3/4"	09.10.2013	Bexa	Rd -----	
		Bearb.	21.08.2013	R&I	
		Gepr.	21.08.2013	pneumatischer Stellantrieb	
		Norm		ZS60-8352	
		verw. Für:	2013.0279.110	Bl.	
		VAM			
Zust.	Änderung	Datum	Name	Urspr.	2013.0020.110
				Ers. f:	Ers. d:

# Pneumatic diaphragm drive Type PPA

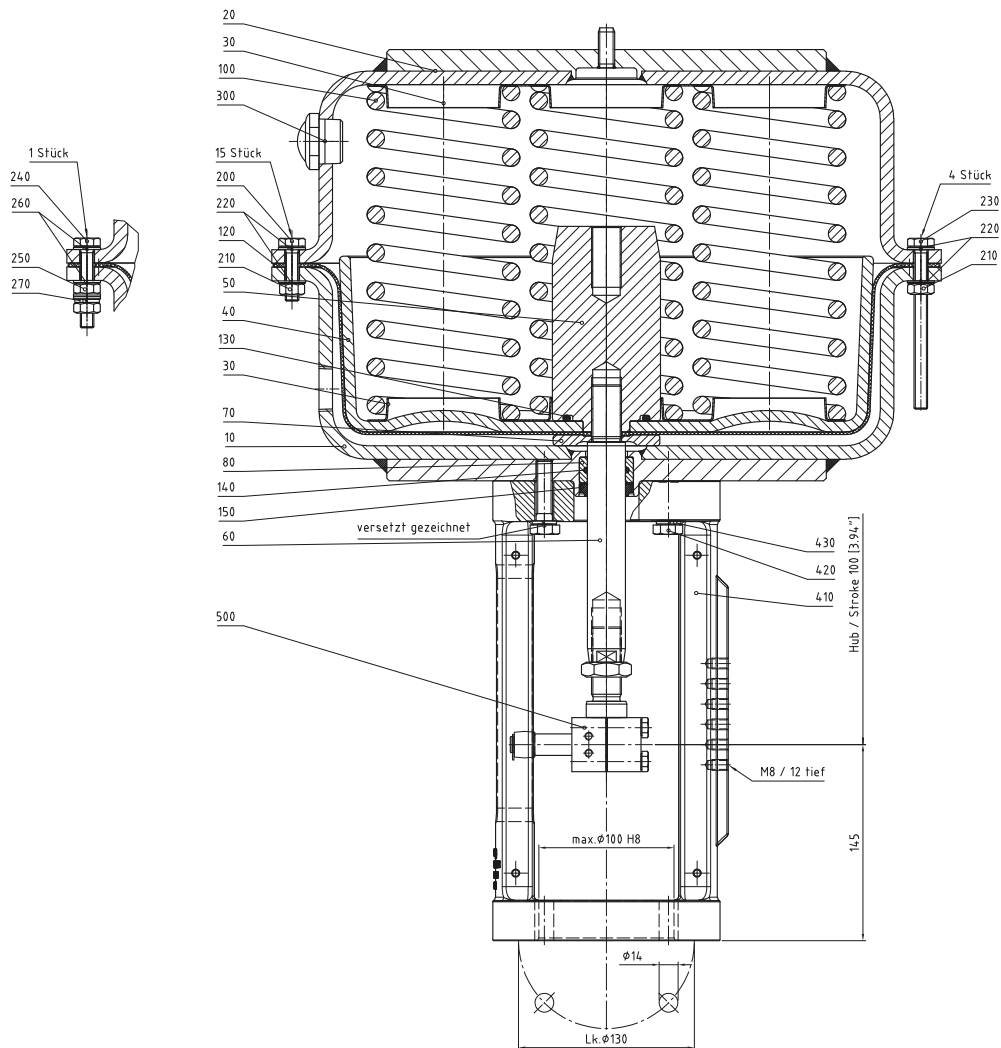

Type of drive		Pneumatic diaphragm drive			
Safety position if air fails	Drive spindle retracted or extended	Type	PPA 300	PPA 600	PPA 1200
		Membrane area	cm <sup>2</sup>	300	600
Strokes		mm	30/50	75	100
max. air pressure		bar	6	6	6
Spring range		bar	0.8...2.7	0.8...2.0	1.0...2.0
		bar	1.2...3.8	1.2...3.0	1.4...3.0
		bar	1.4...4.5	1.4...3.5	1.6...3.6
Air connection		–	1/4" NPT	3/4" NPT	1" NPT
Material	Housing	–	Steel		
	Membrane	–	NBR		
Spindle seal		–	Shaft seal O-ring with support bearing ring		
Optional		–	Handwheel top mounted		

# Pneumatic piston drive Type STPK

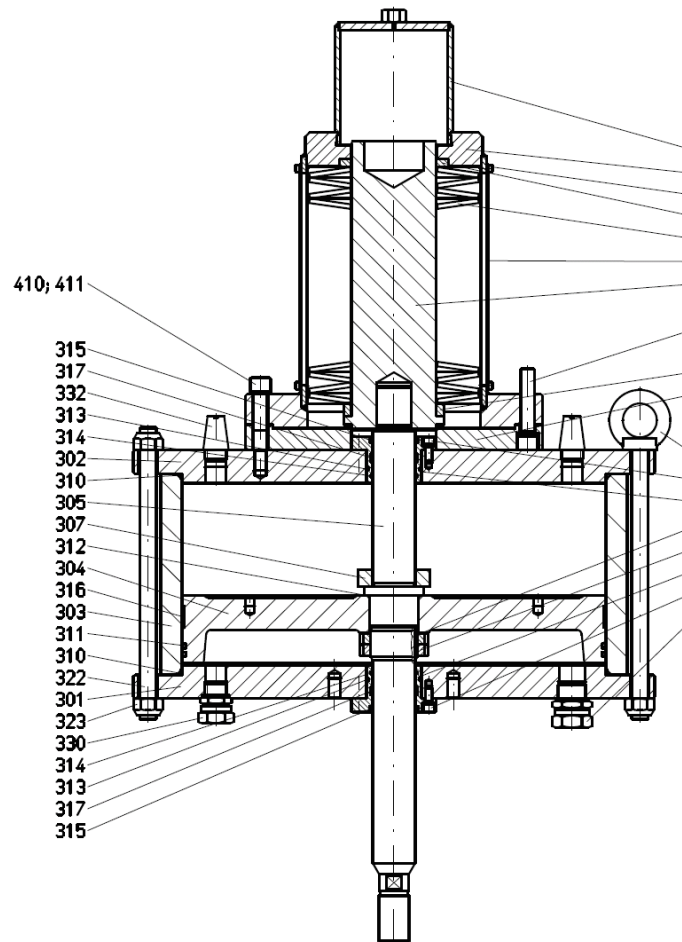

Type of drive		Pneumatic piston drive					
Safety position if air fails	Drive spindle extended	Type	STPK 250	STPK 300	STPK 500	STPK 600	STPK 700
	Drive spindle retracted	Type	special	special	special	special	special
Piston area		cm <sup>2</sup>	490	950	1950	2800	3820
Stroke		mm	80	125	150	150	200
Air feed		bar	6	6	6	6	6
Spring range adjustable	Start of stroke	bar	0.5...2.6	0.5...2.6	0.5...2.6	0.5...2.6	0.5...2.6
	End of stroke	bar	2.0...4.5	2.0...4.5	2.0...4.5	2.0...4.5	2.0...4.5
Air connection		–	G 3/4", G1"				
Material	Housing	–	Aluminium 3.2341.61 / Steel 1.0425				
	Pistons	–	Steel with O-ring seal from EPDM with supporting ring from PTFE				
Spindle seal		–	O-ring from EPDM with supporting ring of PTFE				
Optional		–	Manual adjustment				
Optional / Certifications			Tripple safety device acc. to EU Directive 97/23/EC				



# Hydraulic piston drive Type PHA

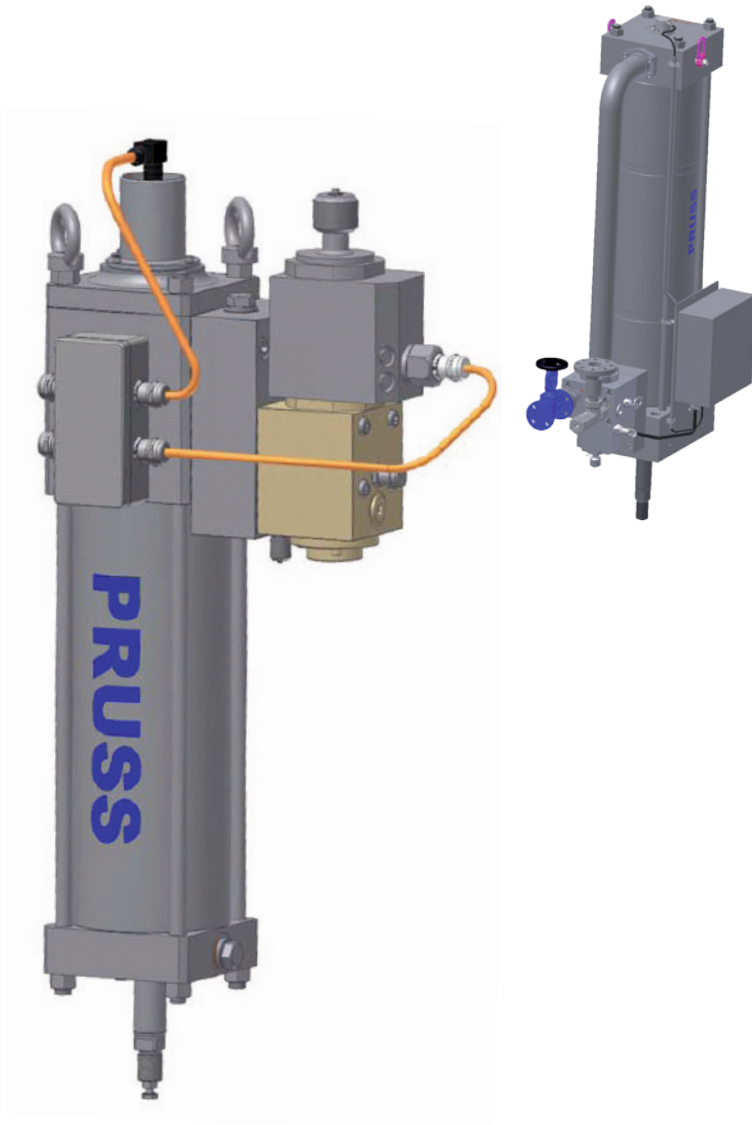

Type of drive		Hydraulic piston drive PN 40				
Safety position if signal fails or pressure falls	Drive spindle extended	Type	special	PHA 110	PHA 125	
	Drive spindle retracted	Type	PHA 100	special	special	
Piston diameter		mm	100	100	125	125
Piston rod diameter		mm	40	50	50	50
Stroke		mm	10	50	30	50
Max. oil pressure		bar	80	80	80	80
Actuating power	Spring	KN	6.8...9.6	15.5...26	15...19.3	18...38.3
	Hydraulic	kN	49.2...39.6	32.4...6.4	50...30.1	40...5.7
Material	Housing	–	Steel			
	Pistons	–	Steel with seal provided by piston ring of PTFE / NBR			
Spindle seal		–	Piston ring of PTFE / NBR			
Optional		–	With solenoid to control switching valves With way valve and encoder to regulate control valves Limit switch, hand pump			

# Hydraulic piston drive Type GZ

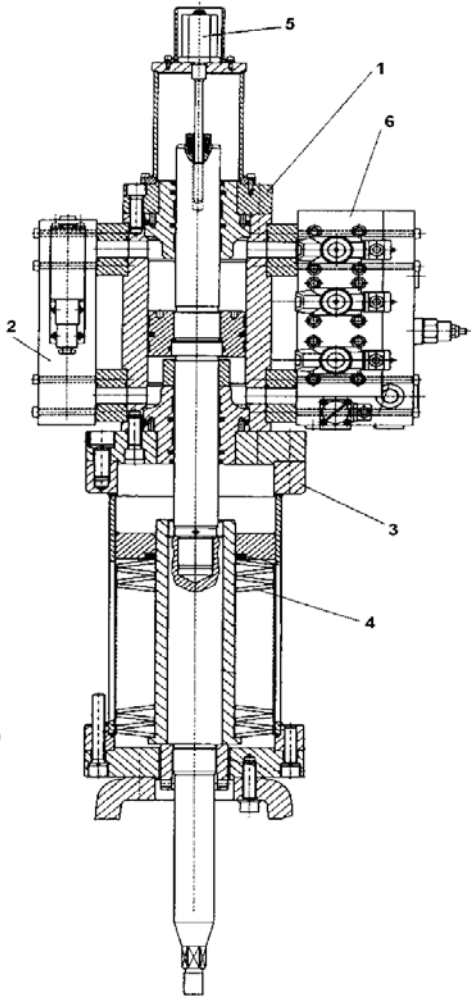

Type of drive		Hydraulic piston drive (synchronising cylinder PN 250)										
Safety position if air fails or pressure falls	Drive spindle extended	Type	GZ 63	GZ 80	GZ 110	GZ 125	GZ 140	GZ 160	GZ 180	GZ 200	GZ 220	GZ 260
	Drive spindle retracted	Type	special	special	special	special	special	special	special	special	special	special
Piston diameter		mm	63	80	110	125	140	160	180	200	220	260
Piston rod diameter		mm	28	30 / 40	40	56	56	60	80	80	90	100
Stroke		mm	100	100 / 200	100	125	150	150	200	200	200	200
Max. oil pressure		bar	220	220	220	220	220	220	220	220	220	220
Spring range		–	Selectable depending on application									
Material	Housing	–	Steel									
	Pistons	–	Steel with seal provided by piston ring of PTFE / NBR									
Spindle seal		–	Piston ring of PTFE / NBR									
Optional		–	With solenoid to control switching valves With position control valve and indicator switch for exact positioning Safety installation to EU Directive 97/23/EC Limit switch, hand pump									

# Hydraulic low-pressure piston drive Type STHK

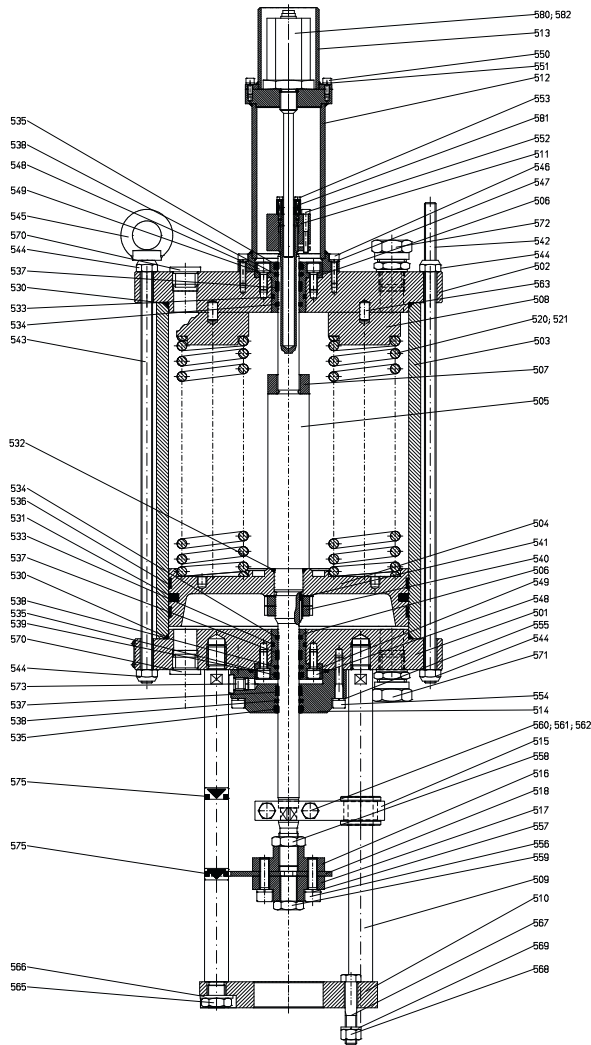

Type of drive		Hydraulic piston drive PN 16		
Safety position if signal fails or pressure falls	Drive spindle extended	Type	STHK 250	STHK 350
	Drive spindle retracted	Type	STHK 250 ÖF	STHK 350 ÖF
Piston diameter		mm	250	350
Piston rod diameter		mm	22	32
Stroke		mm	10 - 150	
Max. oil pressure		bar	15	15
Material	Housing	–	Steel / Aluminium	
	Pistons	–	Steel with seal provided by piston ring of PTFE / NBR	
Spindle seal		–	Piston ring of PTFE / NBR	
Optional		–	Solenoid to control switching valves Way valve and encoder to regulate control valves Limit switch, hand pump	

# Hydraulic stations

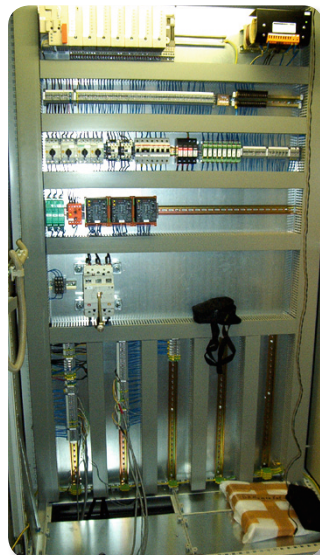

Hydraulic station standard					
Oil	100 litres	160 litres	250 litres	400 litres	600 litres
Type	HSS 100	HSS 160	HSS 250	HSS 400	HSS 600
Motor output KW	1.5 - 2.2	2.2 - 4.0	4.0 - 7.5	7.5 -13.0	18.5
Pump output litres/min	4 - 5.5	5.5 - 11	11 - 22	22 - 31	44
Motors	2	2	2	2	2
Bladder accumulator capacity	10 - 32 litres	32 - 50 litres	32 - 50 litres	32 - 50 litres	32 - 50 litres
Operating fluid	HLP oil	HLP oil	HLP oil	HLP oil	HLP oil
Oil tank	Steel	Steel	Steel	Steel	Steel
Oil sump	Steel	Steel	Steel	Steel	Steel
Solenoids voltage	24 V DC	24 V DC	24 V DC	24 V DC	24 V DC
Level and temperature sensor	binary/analogue	binary/analogue	binary/analogue	binary/analogue	binary/analogue
Pressure transducer 4 - 20 mA	Barksdale	Hydac	Hydac	Hydac	Hydac
Max. operating pressure	250 bar	250 bar	250 bar	250 bar	250 bar
Optional	Special seals for FRF service Stainless steel oil tank Oil cooler (water cooler / air cooler) Analogue level sensor (type as requested by customer) Oil heating Separate loading solenoid valves per motor Protective hood for outdoor use Special pressure transducer, ABB, Siemens, Rosemount Fire-resistant Quintolubric oil Special voltages, solenoid valves, AC, DC				





**Waldemar Pruss Armaturenfabrik GmbH**

Schulenburg Landstraße 261 · 30419 Hannover, Germany  
Telephone: +49 (0) 511 279 86-0 · Fax: +49 (0) 511 279 86-87  
E-Mail: info@pruss.de · Internet: www.pruss.de